

Instruction Manual

Drystar® EDP80 (50 Hz), EDP80 (60 Hz), EDP160 (50 Hz), EDP160 (60 Hz), EDP250 (50/60 Hz), EDP400 (50 Hz) and EDP400 (60 Hz) Chemical Dry Vacuum Pumps

Description	Item Number
Drystar EDP80 (50 Hz) Bareshaft Pump	A70545000
Drystar EDP80 (60 Hz) Bareshaft Pump	A70547000
Drystar EDP160 (50 Hz) Bareshaft Pump	A70544000
Drystar EDP160 (60 Hz) Bareshaft Pump	A70546000
Drystar EDP250 (50/60 Hz) Bareshaft Pump	A70543000
Drystar EDP400 (50 Hz) Bareshaft Pump	A70542000
Drystar EDP400 (60 Hz) Bareshaft Pump	A70541000

Note: The Item Numbers listed above are for Bareshaft Pumps, without a motor. However, this manual contains general information on how to connect a motor to the electrical supply, and on how to replace a motor. The EDP Pumping System instruction manual you will receive will define the build specification of your pump; that is, the type of motor and any ordering options and accessories fitted. You will also receive a motor instruction manual specific to the motor fitted to your pump.

Original Instructions



This page has been intentionally left blank.

Contents

Section	Page
1 Introduction	1
1.1 Scope and definitions	1
1.2 The EDP pumps	1
1.3 Shaft-seals purge	2
1.4 Temperature control system	2
1.5 Pressure relief valve (EDP250 and EDP400 only)	3
1.6 Drive operation	3
1.6.1 Introduction	3
1.6.2 Drive coupling operation	3
1.6.3 Torque limiter operation	3
1.7 Pump frame	4
1.8 Pump motor applicability	7
1.9 Hazardous area and safe area versions of the pump	7
1.10 Accessories	7
1.11 Ordering options	7
1.12 Normal/abnormal operation	7
1.12.1 Normal operation	7
1.12.2 Abnormal operation	8
2 Technical data	9
2.1 Operating and storage conditions	9
2.2 Performance	9
2.3 Mechanical data	10
2.4 Electrical data	10
2.5 Shaft-seals purge nitrogen supply data	10
2.6 Temperature control system	11
2.7 Cooling-water data	11
2.8 Coolant type	12
2.9 Lubrication data	12
2.10 Noise data	13
2.11 Connections	13
2.12 Materials of construction	16
3 Installation	17
3.1 Safety	17
3.2 Unpack and inspect	17
3.3 Locate the pump	18
3.4 Check the coolant level	18
3.5 Check the gearbox oil-level	20
3.6 Electrical connections	20
3.6.1 Introduction	20
3.6.2 Connect the electrical supply to the pump-motor	21
3.6.3 Connect the pump coolant jacket temperature sensor: introduction	21
3.6.4 Connect the thermal snap-switch (if fitted)	22
3.6.5 Connect the temperature transmitter (if fitted)	22
3.7 Check the direction of pump rotation	24
3.8 Connect the cooling-water supply	26
3.9 Connect the shaft-seals purge nitrogen supply	26
3.10 Connect the pump-inlet and outlet	28
3.10.1 Connect the pump-inlet to your process system	28
3.10.2 Connect the pump-outlet to your exhaust system	29
3.11 Leak test the installation	29

2021-VIN-GCN-0038

3.12	Commission the pump	30
3.12.1	Adjust the thermal snap-switch (if fitted)	30
3.12.2	Adjust the pump coolant jacket trip temperature (pumps fitted with a temperature transmitter, if required) 30	
3.12.3	Commissioning procedure	30
3.12.4	Adjust the TCV (thermostatic control-valve)	31
4	Operation	33
4.1	Operational safety	33
4.2	ATEX system control	33
4.3	Non-ATEX system control	34
4.3.1	Start the pump	34
4.3.2	Allow the pump to warm up	34
4.3.3	Shut down the pump	35
4.4	Inspect and reset the torque limiter (pumps with a torque limiter only)	35
5	Maintenance	37
5.1	Safety	37
5.2	Maintenance plan	37
5.3	Check the gearbox oil-level and fill the gearbox with oil (if necessary)	38
5.4	Check the shaft-seals purge supply	39
5.5	Remove the inlet filter	39
5.6	Inspect the pipelines and connections	41
5.7	Inspect the pressure relief valve and replace the hinge bushes, flap and O-ring (if necessary): EDP250 and EDP400 only 41	
5.7.1	Remove the valve from the pump	41
5.7.2	Clean and inspect the valve	41
5.7.3	Refit the valve to the pump	42
5.7.4	Leak test the pump	42
5.8	Change the pump oil and clean the oil-level sight-glasses	42
5.9	Relubricate/inspect the rotor bearings	44
5.9.1	Introduction	44
5.9.2	Remove the bearing cover and bearing caps	45
5.9.3	Clean, inspect and relubricate the rotor bearings	45
5.9.4	Refit the bearing caps and bearing cover	46
5.9.5	Leak test the pump	46
5.10	Check the coolant level and refill if necessary	47
5.10.1	Refill the pump with Edwards coolant	47
5.10.2	Fill the pump with a different coolant	47
5.10.3	Check for coolant leaks	48
5.11	Flush the pump with cleaning solution	48
5.11.1	Introduction	48
5.11.2	Flush a pump which has been operating	48
5.11.3	Flush a seized pump	50
5.12	Clean the cooling system	53
5.12.1	Drain the coolant from the cooling system	53
5.12.2	Clean the cooling-water filter	53
5.12.3	Clean the cooling-water flow indicator	53
5.12.4	Clean the heat exchanger	55
5.12.5	Prepare the pump for operation	56
5.13	Overhaul the pump	56
5.14	Replace the pressure relief valve (EDP250 and EDP400 only)	56
5.15	Inspect the torque limiter	56
5.15.1	Lower the pump-motor and coupling cover (without the motor change frame)	56
5.15.2	Lower the pump-motor and coupling cover (with the motor change frame)	57
5.15.3	Remove the coupling cover from the pump-motor	58
5.15.4	Replace the drive coupling element	58
5.15.5	Remove the drive hub and fit to the new pump-motor (pumps without a torque limiter)	58
5.15.6	Remove the torque limiter and fit to the new pump-motor (pumps with a torque limiter)	58

5.15.7	Fit the coupling cover to the new pump-motor	60
5.15.8	Refit the pump-motor and coupling cover to the pump (without the motor change frame)	60
5.15.9	Refit the pump-motor and coupling cover to the pump (with the motor change frame)	61
5.16	Fit a replacement service module	65
5.16.1	Introduction	65
5.16.2	Prepare the pump	66
5.16.3	Remove the old service module	66
5.16.4	Inspect the components removed from the service module	67
5.16.5	Fit the new service module	67
5.17	Fault finding	70
6	Storage and disposal	73
6.1	Storage	73
6.2	Disposal	73
7	Service and spares	75
7.1	Introduction	75
7.2	Service	75
7.2.1	Return the equipment or components for service	75
7.3	Spares and maintenance kits	76
7.4	Accessories	76
7.5	Ordering options	76
	Index	77

Illustrations

Figure	Page	
1	The EDP pump: sheet 1 of 2	5
2	EDP pump dimensions: mm (sheet 1 of 2)	14
3	Fill the pump with coolant	19
4	Services panel	25
5	Flange loading limits	27
6	Oil-level sight-glass and oil filling and draining connections	40
7	Exploded view of the pressure relief valve	43
8	Exploded view of an oil-level sight-glass	46
9	Relubricate the rotor bearings	49
10	Flush the pump	52
11	Clean the cooling-water filter	54
12	Clean the cooling-water flow indicator	55
13	Clean the heat exchanger	59
14	Exploded view of the pump-motor, torque limiter and coupling cover (pumps with a torque limiter) ..	62
15	Exploded view of the pump-motor, coupling drive and coupling cover (pumps without a torque limiter) ..	63
16	Use the motor change frame to lower the pump-motor and coupling cover assembly	64
17	Remove/refit the service module	69

Tables

Table		Page
1	Operating and storage conditions	9
2	Performance data	9
3	Mechanical data	10
4	Electrical data	10
5	Shaft-seals purge nitrogen supply data	10
6	Temperature control system data	11
7	Cooling-water data	11
8	Possible alternative coolants	12
9	Lubrication data	12
10	Noise data	13
11	Connections	13
12	Materials of construction	16
13	TCV settings	31
14	Maintenance plan	38
15	Recommended rotor bearing relubrication frequencies	44
16	O-rings supplied with the replacement service module	68
17	Fault finding	70
18	Spares and maintenance kits	76

Trademark credits

Edwards and the Edwards logo are trademarks of Edwards Limited, Innovation Drive, Burgess Hill, West Sussex RH15 9TW.

Drystar® is a registered trademark of the Edwards group plc.

1 Introduction

1.1 Scope and definitions

This manual provides installation, operation and maintenance instructions for the Edwards Drystar EDP80, EDP160, EDP250 and EDP400 Chemical Dry Vacuum Pumps. You must use the EDP pumps as specified in this manual.

Read this manual before you install and operate your pump. Important safety information is highlighted as WARNING and CAUTION instructions; you must obey these instructions. The use of WARNINGS and CAUTIONS is defined below.



WARNING

Warnings are given where failure to observe the instruction could result in injury or death to people.

CAUTION

Cautions are given where failure to observe the instruction could result in damage to the equipment, associated equipment and process.

The following IEC warning labels appear on the pump:



Warning - refer to accompanying documentation.



Warning - risk of electric shock.



Warning - hot surfaces.

The units used throughout this manual conform to the Imperial and US units of measurement.

1.2 The EDP pumps

Note: The EDP pumps can be used as components in ATEX certified systems. As components, the EDP pumps are not assigned ATEX qualification.

The EDP pumps are rugged, reliable dry vacuum pumps designed specifically for use in the chemical and pharmaceutical processing industries. The pump is mounted vertically in a frame (Figure 1, item 6); this configuration ensures that liquids in the process gases easily drain through the pump.

The pump is a three-stage, positive displacement rotary pump in which pairs of intermeshing rotors (mounted on common shafts) are held in correct phase relation by a pair of timing-gears. The timing-gears and the adjacent double-row angular contact ball bearings are oil lubricated.

A lip-seal arrangement is used to provide a high-integrity seal between the gearbox oil and atmosphere.

1.3 Shaft-seals purge

Refer to [Figure 1](#). The shaft-seals purge pipeline (17) delivers a nitrogen purge to the shaft-seals.

This shaft-seals purge system:

- Ensures that the shaft-seals are maintained at a positive pressure during pump operation.
- Prevents the entry of corrosive or toxic process vapours into the pump gearbox.
- Prevents contamination of the process gases by pump oil.
- Prevents damage to the shaft-seals by debris.

Accessory kits are available to provide final stage gas ballast and inlet purge facilities on the pump: refer to [Section 7.4](#).

1.4 Temperature control system

Refer to [Figure 1](#). The pump has an indirect cooling system. Coolant circulates around the pump-body by natural convection; the coolant then passes through a secondary circuit in the heat exchanger (22). In the heat exchanger, heat is extracted from the coolant by cooling-water which circulates through a primary circuit in the heat exchanger. The pump-body has a coolant overflow pipe (20). As the temperature of the pump-body increases and the coolant expands, excess coolant may be forced out of this pipe. This pipe is coiled up for delivery purposes. On installation it should be routed to a suitable container. The quantity of coolant ejected will give an indication of whether a top up is required.

In operation, the pump is maintained at a constant temperature by a TCV (thermostatic control-valve, 7) which controls the supply of cooling-water to the heat exchanger. The pump-motor (12) is air-cooled.

The cooling-water supply passes through a filter ([Figure 4](#), item 10) and then through a pipeline to the heat exchanger (22). A flow indicator ([Figure 4](#), item 11) in the cooling-water return pipeline shows when there is a flow of cooling-water through the heat exchanger.

The EDP pump has a coolant jacket upper temperature limit that is defined by:

- The pump operating limit (for non-ATEX applications).
- The temperature classification (if the EDP is part of an ATEX system).

In order to monitor the pump temperature and to provide a means of switching off the pump when the coolant jacket temperature is too high, the EDP pump will be fitted with one of the following:

- A temperature transmitter.
- A thermal snap-switch*.

Refer to [Section 3.6.4](#) and [3.6.5](#) for connection details.

* Non-ATEX systems only.

1.5 Pressure relief valve (EDP250 and EDP400 only)

The EDP250 and EDP400 pumps have a pressure relief valve (Figure 1, item 26) fitted in a pipe between the pump-outlet and the last stage of the pump. The valve is normally held closed by its own weight, but opens depending on the pump-inlet pressure, as follows:

- At pump-inlet pressures of 300 mbar (3×10^4 Pa) and above on the EDP250, and at pump-inlet pressures of 200 mbar (2.0×10^4 Pa) and above on the EDP400, the interstage pressure forces the valve open. This allows process gases to pass directly from the second stage into the pump-outlet, without compression in the third stage of the pump.
- At pump-inlet pressures below those specified above, the interstage pressure is low and the valve is held closed. Process gases pass through all stages of the pump; that is the process gases are compressed in the third stage before they pass into the pump-outlet.

The pressure relief valve allows the pump to maximise pumping speed from atmospheric pressure down to 10 mbar (1×10^3 Pa) and also prevents excessive electrical power consumption by the pump-motor when the pump starts.

1.6 Drive operation

1.6.1 Introduction

The EDP250 and EDP400 pumps have a torque limiter. The torque limiter provides mechanical protection for the pumping mechanism, from excess liquid in the process gas stream.

The basic EDP80 and EDP160 pumps have a drive coupling, however you can order these pumps to be supplied with a torque limiter fitted (refer to Section 1.11). Refer to Section 1.6.2 for a description of the drive coupling operation, and refer to Section 1.6.3 for a description of the torque limiter operation. Refer to torque limiter amendment for details of operation and maintenance.

1.6.2 Drive coupling operation

Note: The EDP80 and EDP160 pumps do not need a torque limiter to protect the pumping mechanism from excess liquid in the process gas stream. The electrical overload facility in the pump-motor provides this protection.

The basic EDP80 and EDP160 pumps have a flexible drive coupling which transmits the drive from the pump-motor to the pump rotors.

Refer to Figure 15. A coupling hub (15) is fitted to the pump shaft (16) and a coupling hub (5) is fitted to the motor shaft (6).

1.6.3 Torque limiter operation



WARNING

If there is a risk that the electrical current monitor in your control system may not detect a torque limiter trip, you must fit a rotation sensor to the pump.

Refer to Figure 1. The pump-motor (12) drives the pump rotors through a torque limiter. When the torque required to turn the pump rotors is excessive (for example, if the pump is accidentally flooded with process liquids), the torque limiter automatically trips. When the torque limiter trips, it decouples the pump-motor from the pump, and the pump-motor no longer drives the pump rotors. This prevents damage to the pumping mechanism.

When the torque limiter trips, the pump-motor will continue to operate, however there will be a significant fall in the electrical current consumed by the pump-motor.

We recommend that:

- Your control equipment should monitor the current consumed by the pump-motor, in order to determine when the torque limiter has tripped.
- When the torque limiter has tripped, your control equipment should switch off the pump-motor; operation in the decoupled state may cause excessive wear to the torque limiter.

The torque limiter is enclosed in the coupling cover which has two removable coupling cover guards (14). You can remove these covers to reset the torque limiter and recouple the pump- motor to the pump (refer to [Section 4.4](#)).

The coupling hub used in the torque limiter (see [Figure 14](#)) is identical to those used in the EDP80 and EDP160 drive coupling. See attached amendment for more details on the torque limiter or coupling.

1.7 Pump frame

Refer to [Figure 1](#). The pump is vertically mounted in a robust frame (6), which has lifting-bolts (5). The frame on EDP250 and EDP400 pumps has lower cross-members (11) which can be used to move the pump with a fork-lift truck.

The cooling-water and purge gas connections are on a services panel (8) on the frame. The TCV (7) is fitted to the rear of the services panel.

Fixing holes (9) in the frame can be used to secure the pump frame in its operating position.

Figure 1 - The EDP pump: sheet 1 of 2

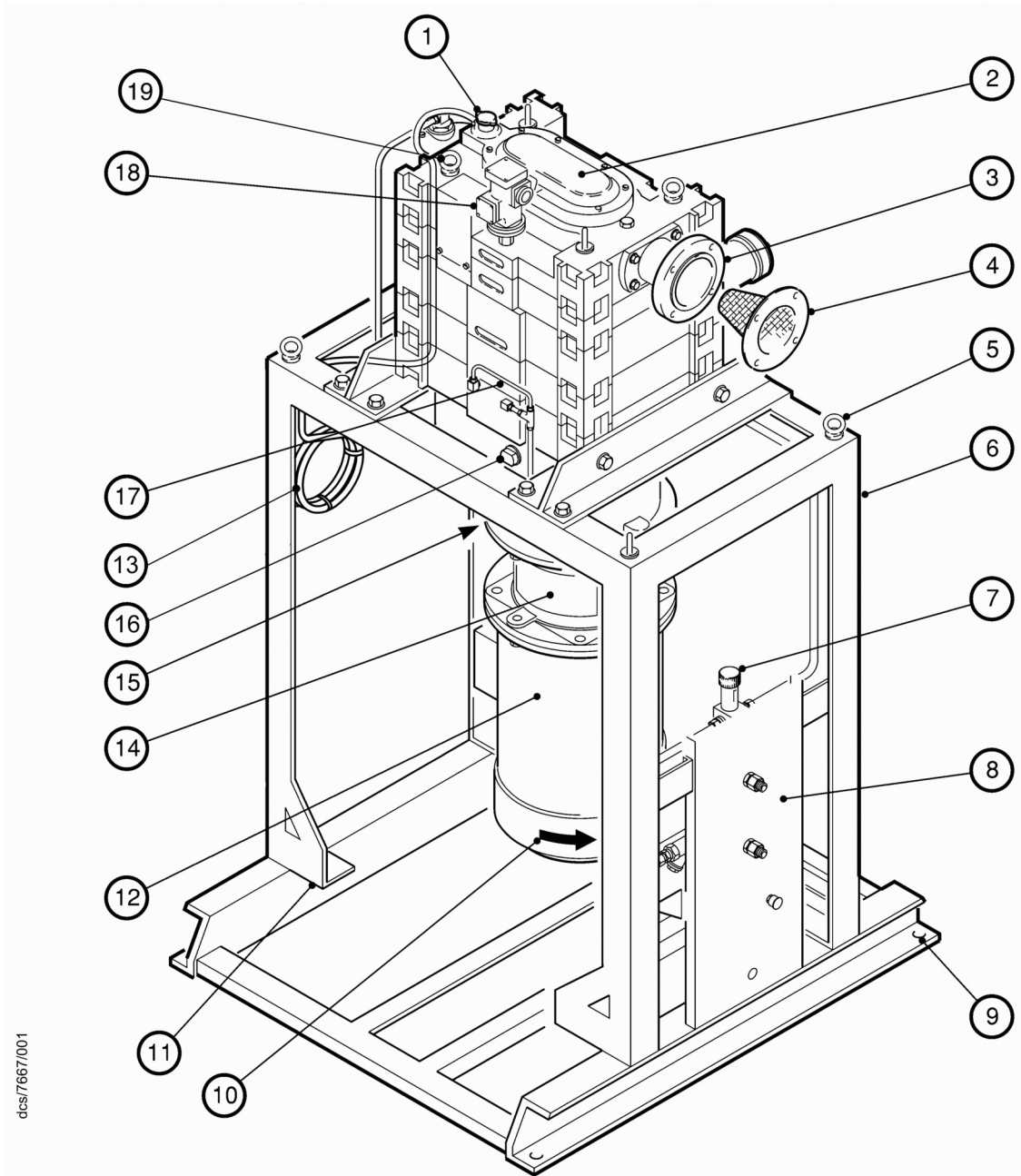

dcs/7667/001

- | | |
|---|--|
| <ul style="list-style-type: none"> 1. Coolant filler cap 2. Bearing cover 3. Pump-inlet 4. Inlet filter (in pump-inlet) 5. Lifting bolt 6. Frame 7. TCV (thermostatic control-valve) 8. Services panel 9. Fixing hole 10. Direction of rotation arrow | <ul style="list-style-type: none"> 11. Frame lower cross member (EDP250/EDP400 only) 12. Pump-motor 13. End of coolant overflow pipe 14. Coupling cover guard 15. Oil-level sight-glass (behind frame) 16. Oil filler-plug 17. Shaft- seals purge pipeline 18. Coolant jacket thermal snap-switch* 19. Service module lifting bolts |
|---|--|

* A temperature transmitter may be fitted instead of a thermal snap-switch: see Section 1.4.

Figure 1 - The EDP pump: sheet 2 of 2

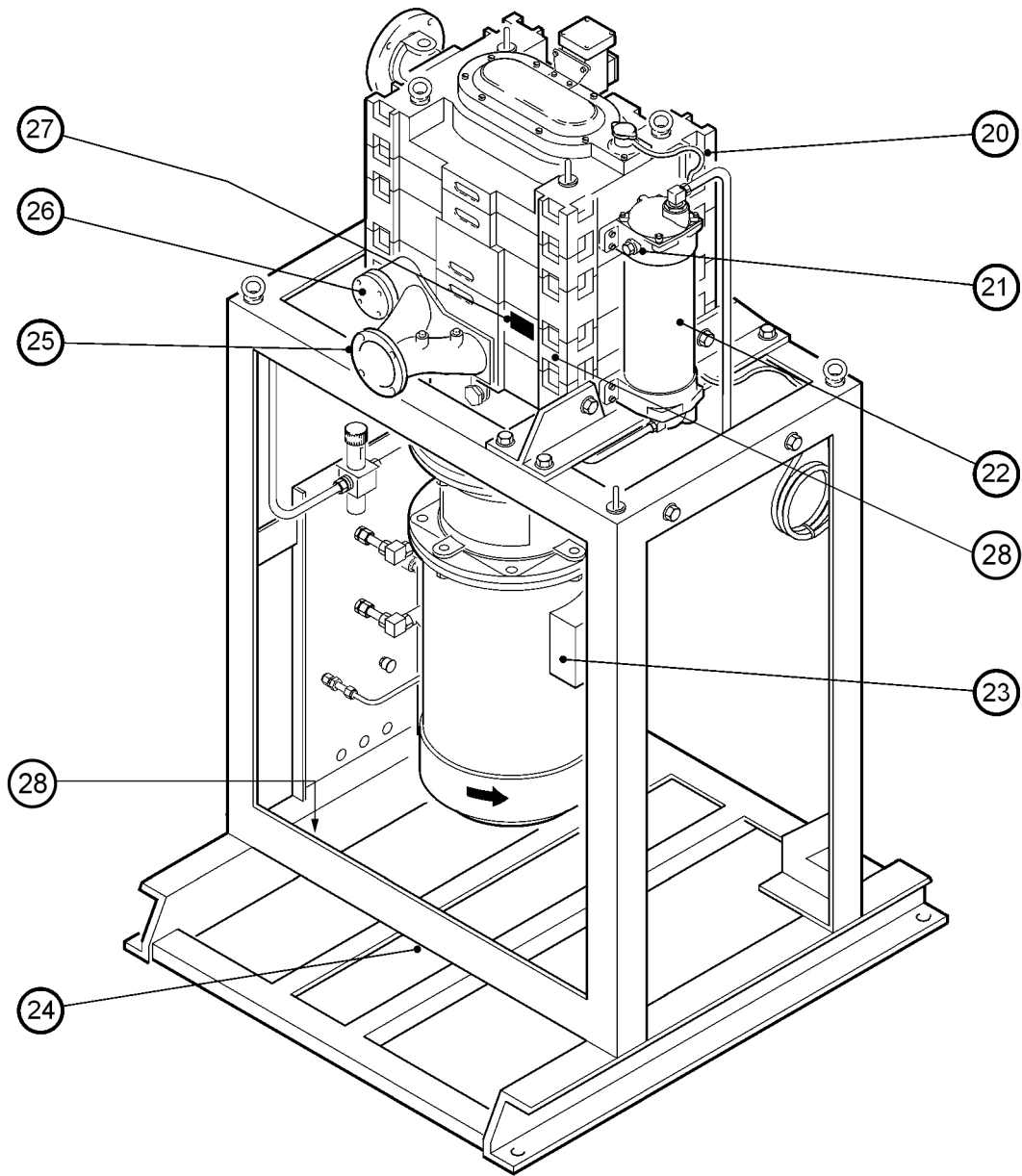

dcsl7667/002

- 20. Coolant overflow pipe
- 21. Bleed plug (EDP80/EDP160 only)
- 22. Heat exchanger
- 23. Pump-motor terminal-box
- 24. Frame lower cross members
- 25. Pump-outlet
- 26. Pressure relief valve (EDP250/EDP400 only)
- 27. Pump case temperature measurement point
- 28. M8 Earth stud

1.8 Pump motor applicability

The Pumping System instruction manual you receive will specify the type of motor fitted to your EDP pump.

Note that you will also receive the appropriate Motor instruction manual for your pump.

The pumps are designed to operate with motors rated as specified in [Section 2.4](#), with the maximum outlet pressures listed in the pump descriptions on the front cover of this manual.

Note that the EDP250 can be configured with two different ratings of motor, one for each of the two different maximum outlet pressures with which the pump is designed to operate.

1.9 Hazardous area and safe area versions of the pump

The EDP pumps are available in versions suitable for Hazardous Area or Safe Area operation.

Refer to your EDP Pumping System instruction manual, which will specify the technical specification of your system. The EDP Pumping System instruction manual will define whether your system is suitable for Safe Area operation only, or will define the Hazardous Area classification in which your system is certified to operate.

1.10 Accessories

A number of accessories are available for the EDP pumps; use these to configure the pump for specific applications. These accessories are listed in [Section 7.4](#).

1.11 Ordering options

The basic EDP80 and EDP160 pumps are supplied with a drive coupling (see [Section 1.6.2](#)) If required, you can order these pumps to be supplied with a torque limiter fitted; refer to [Section 1.6.3](#) for a description of the torque limiter operation.

1.12 Normal/abnormal operation

1.12.1 Normal operation

Normal operation is defined by this instruction manual. In normal operation, the EDP pump is safe to handle gases from gas groups IIA, IIB and IIC if no flame arresters are fitted. If flame arresters are fitted the designation of the flame arresters will determine the gas group that can be pumped with the pumping system. Please also read the exceptions listed in [Section 1.12.2](#).

If the EDP pump is to be used in a non-ATEX system:

- We recommend that you fit approved flame arrestors to the EDP pump, if you intend to pump potentially explosive atmospheres.

If the EDP pump is to be used as part of an ATEX system:

- The use of approved flame arrestors is mandatory for some ATEX system classifications. Refer to the ATEX System instruction manual for more information.

1.12.2 Abnormal operation



WARNING

Misuse of the EDP pump as described below is strictly prohibited:

- Use of the EDP pump as a positive pressure compressor.
- Use of the EDP pump whilst subjected to high back-pressure (for example, caused by a blockage in the exhaust pipeline). Refer to [Section 2.2](#) for the system limitation.
- Pumping gases that cause the inlet flame arrestor (where fitted) or associated pipelines to exceed a surface temperature of 40 °C.
- Reverse rotation of the EDP pump.
- Pumping hydrocarbon oxides.
- Pumping gases that tend to self-decompose, or that are chemically unstable.
- Use of the EDP pump with materials which have auto-ignition temperatures below the defined temperature rating.
- Operation such that the pump inlet temperature falls below the dew point of a flammable vapour being pumped. This could lead to condensate that can collect and lead to the risk of corrosion or an ignition hazard.
- Pumping of, or use of the EDP pump in the presence of, explosive dust atmospheres.
- Use of the EDP in a system or flammable process that causes the ingress of metallic particles into the pump.
- Use of the EDP pump in ambient conditions other than those specified in [Section 2.1](#).
- Pumping pyrophoric gases.
- Use with oxygen enriched atmospheres.
- Use in an external atmosphere where there is a potentially flammable dust atmosphere.
- Use of the EDP pump in a potentially explosive external atmosphere, unless the pumping system is certified as compliant with ATEX Directive 2014/34/EU (European Union only).

2 Technical data

2.1 Operating and storage conditions

Note: If you operate the pump in an ambient temperature between -20 and -5 °C, we recommend that you leave the pump constantly operating and only shut down the pump for maintenance purposes.

Table 1 - Operating and storage conditions

Ambient operating temperature range	-15 to 40 °C
Maximum ambient operating humidity	90% RH
Maximum operating altitude	1000 m
Environment	External, industrial location
Warm-up time *	60 min (EDP80), 45 min (EDP160/250/400)
Cool-down time †	3 h

* To a pump operating temperature of 55 °C.

† To a safe temperature for maintenance.

2.2 Performance

Table 2 - Performance data

	EDP80		EDP160		EDP250		EDP400		
	50 Hz	60 Hz	50 Hz	60 Hz	50 Hz	60 Hz	50 Hz	60 Hz	
Maximum pumping speed:	m ³ h ⁻¹ cfm	83 49	102 60	163 96	202 119	260 153	301 177	385 227	425 250
Displacement (swept volume):	m ³ h ⁻¹ cfm	98 58	163 96	197 116	238 140	315 185	379 223	540 318	595 350
Ultimate vacuum:	mbar Torr Pa	0.6 0.45 60	0.33 0.25 33	0.5 0.38 50	0.33 0.25 33	0.4 0.3 40	0.2 0.15 20	0.4 0.3 40	0.2 0.15 20
Maximum outlet pressure:	bar abs Pa psi g	1.3 1.3x10 ⁵ 4.4	1.3 1.3x10 ⁵ 4.4	1.15 1.15x10 ⁵ 2.2	1.3 1.3x10 ⁵ 4.4	1.15 1.15x10 ⁵ 2.2	1.3 1.3x10 ⁵ 4.4	1.15 1.15x10 ⁵ 2.2	1.15 1.15x10 ⁵ 2.2
*Refer to Note 1 below	bar abs Pa psi g			1.3 1.3x10 ⁵ 4.4		1.3 1.3x10 ⁵ 4.4			
Motor power	kW HP	5.5 7.5	5.5 7.5	7.5 10	11 15	11 15	15 20	18.5 25	22 30

* Note 1: Exhaust pressure up to this limit will require the next increment motor power which is also listed in the above table.

2.3 Mechanical data

Note: Refer to the motor manual supplied with your pump for the mass of the motor.

Table 3 - Mechanical data

Dimensions		Refer to Figure 2							
		EDP80		EDP160		EDP250		EDP400	
		50 Hz	60 Hz	50 Hz	60 Hz	50 Hz	60 Hz	50 Hz	60 Hz
Mass (without motor):	kg	625	699	700	799	825	826	875	870
	lb	1378	1540	1543	1760	1819	1820	1929	1920
Coolant capacity:	kg			798					
	lb			1759					
Cleaning solution (see Section 5.11):	l	12.5	12.5	15	15	15.9	15.9	16.8	17.41
	US gal	3.3	3.3	4	4	4.2	4.2	4.44	4.6
Cleaning solution (see Section 5.11):	l	5	5	7	7	8.5	8.5	9.6	9.6
	US gal	13	1.3	1.8	1.8	2.25	2.25	2.5	2.5

2.4 Electrical data

Table 4 - Electrical data

		EDP80		EDP160		EDP250		EDP400	
		50 Hz	60 Hz	50 Hz	60 Hz	50 Hz	60 Hz	50 Hz	60 Hz
Nominal electrical supply frequency:	Hz	50	60	50	60	50	60	50	60
Rotational speed:	r min ⁻¹	2940	3580	2940	3580	2940	3580	2940	3580
Motor rating	kW	5.5	5.59	7.5	11.2	11	14.9	18.5	22.4
	h.p.	7.38	7.5	10	15	14.8	20	24.8	30

2.5 Shaft-seals purge nitrogen supply data

Table 5 - Shaft-seals purge nitrogen supply data

		Minimum	Maximum
Supply pressure	bar g	2.00	10
	Pa	3×10^5	1.1×10^6
	psi g	29	145
Regulated pressure to shaft-seals	bar	0.3	0.5
	Pa	3×10^4	5×10^4
	psi g	5	7

2.6 Temperature control system



WARNING

If your pump is part of an ATEX system, it may have an operating case temperature limit. Refer to the ATEX System instruction manual for details.

Table 6 - Temperature control system data

Water cooling system	
Type	Indirect water-to-coolant heat exchanger
Coolant capacity	Refer to Table 3
TCV (Thermostatic Control valve)	10 to 90 °C
Sensor operating temperature range	50 to 175 °F
Maximum sensor temperature	130 °C 265 °F
Thermal snap-switch	
Operating temperature range	50 to 100 °C 120 to 212 °F
Contact rating	
Maximum voltage	240 V
Maximum current (inductive load)	5 A (inductive) 12 V (resistive)

2.7 Cooling-water data

Table 7 - Cooling-water data

Supply temperature range	5 to 35 °C 40 to 95 °F							
Maximum supply pressure	10 bar, 1 x 10 ⁶ Pa, 145 psi g							
Minimum required pressure differential across supply and return	2.1 bar, 2.1 x 10 ⁵ Pa, 30 psi g							
	EDP80		EDP160		EDP250		EDP400	
	50 Hz	60 Hz	50 Hz	60 Hz	50 Hz	60 Hz	50 Hz	60 Hz
Typical heat removed from pump by cooling-water	2.5 kW 8540 BTU/h	3 kW 10240 BTU/h	4 kW 13660 BTU/h	4 kW 13660 BTU/h	5 kW 17100 BTU/h	5 kW 17100 BTU/h	5 kW 17100 BTU/h	5 kW 17100 BTU/h
Maximum water consumption Pump operating temperature 55 °C/131 °F	150 l/h 40 US gal/h	150 l/h 40 US gal/h	270 l/h 72 US gal/h	270 l/h 72 US gal/h	270 l/h 72 US gal/h	270 l/h 72 US gal/h	330 l/h 84 US gal/h	330 l/h 84 US gal/h

2.8 Coolant type

The pump is supplied filled with Edwards coolant which is monopropylene based, and is both an antifreeze and a corrosion inhibitor. Spare Edwards coolant is available: refer to [Section 7.3](#). If you will use another coolant type to replenish lost coolant:

- It must prevent the formation of visible oxide sludge and scale deposits.
- It must provide frost protection down to a temperature of -14 °C, when mixed in accordance with the manufacturer’s recommendations.
- It must be compatible with the materials of construction of the cooling-jacket; that is: SG iron, copper, brass and fluoroelastomer (Viton) seals.
- It must comply with the requirements of BS 6580-1992 and BS 5117.
- It must be based on monopropylene glycol or ethylene glycol fluid.
- It must not contain amines.

The coolants shown in [Table 8](#) may be suitable for use in the EDP pumps. All of these coolants are amine free, automotive grade, ethylene glycol antifreezes and must be diluted to between 35% to 50% by volume with water to provide the required cooling protection. However, we recommend that you use Edwards coolant; Edwards cannot guarantee that other types of coolant will provide the best corrosion protection for the pump.

Table 8 - Possible alternative coolants

Manufacturer	Product
BP (Chemicals)	NAPGEL C2230 (Universal)
Texaco Lubricants	Texaco Engine Coolant ETX 6024
Castrol	Castrol Antifreeze

2.9 Lubrication data

Note: Edwards Material Safety Data Sheets for some of the oils and greases specified below are available on request.

Table 9 - Lubrication data

Gearbox	
Oil capacity: minimum	3.35 l / 0.89 US gal
Oil capacity: maximum	3.85 l / 1.02 US gal
Recommended oil (supplied)	Mobil SHC 629
High vacuum bearings	
Grease type	Perfluoropolyether
Recommended grease	Fomblin CR861

2.10 Noise data

Table 10 - Noise data

	EDP80		EDP160		EDP250		EDP400	
	50 Hz	60 Hz	50 Hz	60 Hz	50 Hz	60 Hz	50 Hz	60 Hz
Typical continuous A-weighted sound pressure level	73 dB(A)	73 dB(A)	78 dB(A)	78 dB(A)	79 dB(A)	79 dB(A)	82 dB(A)	82 dB(A)

2.11 Connections

Table 11 - Connections

Pump-inlet connection		
EDP80	50 Hz 60 Hz	2 inch ANSI 150 lbf raised face flange
EDP160, EDP250, EDP400	50 Hz 60 Hz	3 inch ANSI 150 lbf raised face flange
Pump-outlet connection		
EDP80, EDP160	50 Hz 60 Hz	1.5 inch ANSI 150 lbf raised face flange
EDP250, EDP400	50 Hz 60 Hz	2 inch ANSI 150 lbf raised face flange
Recommended pump-inlet and pump-outlet seals		PTFE envelope gaskets: 'KLINGER' milled type with a 1.5 mm full-face insert
Shaft-seals purge nitrogen inlet		1/4 inch compression fitting
Cooling-water supply		
Inlet	50 Hz	1/2 inch BSP female
Outlet	50 Hz	1/2 inch BSP female
Inlet	60 Hz	1/2 inch NPT female
Outlet	60 Hz	1/2 inch NPT female
Middle-stage and gas-ballast purge port fittings type		
EDP80		1/4 inch BSP
EDP160, EDP250, EDP400		1/2 inch BSP

Figure 2 - EDP pump dimensions: mm (sheet 1 of 2)

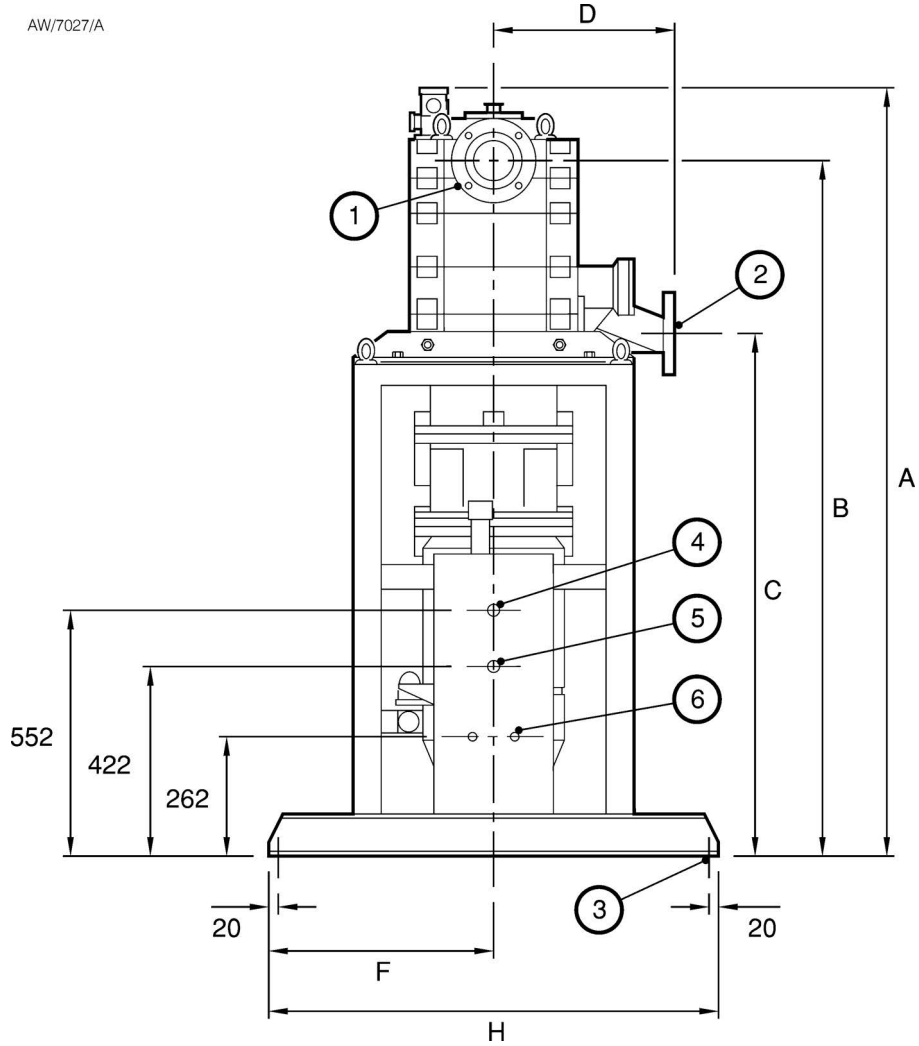

- 1. Pump-inlet
- 2. Pump-outlet
- 3. Fixing hole: Ø18 mm (4 off)
- 4. Cooling-water outlet connection
- 5. Cooling-water inlet connection
- 6. Nitrogen supply inlet connection

Figure 2 - EDP pump dimensions: mm (sheet 2 of 2)

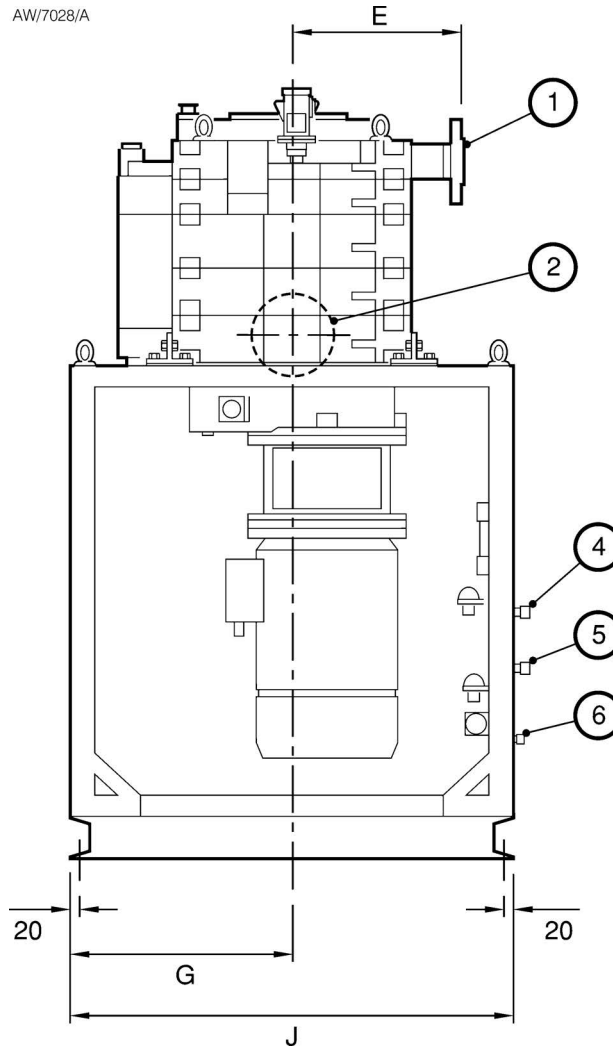

Key	EDP80	EDP160	EDP250	EDP400 50 Hz	EDP400 60 Hz
A	1423	1458	1681	1730	1721
B	1254	1289	1514	1562	1549
C	974	974	1148	1148	1149
D	353	353	377	377	349
E	443	448	359	359	362
F	350	350	500	500	476
G	350	350	475	475	476
H	700	700	1000	1000	997
J	850	850	950	950	946

2.12 Materials of construction

Table 12 - Materials of construction

Component	Materials
Stator Rotor Heat exchanger housing	Cast iron
Shafts Gears	Steel
Bearing housing Shaft sleeves Throwers Valve body Valve seat Valve pad	Steel
Sleeves	Steel
Shims	Stainless steel
Piston rings	Steel
Lip seals	Stainless steel 316/PTFE
Case O-rings	Viton
Valve O-ring	FEP coated Viton
Heat exchanger end caps	Cast iron
Heat exchanger tube stack	Cupro-nickel
Heat exchanger tubestack baffles and end plates	Brass

3 Installation

3.1 Safety



WARNING

Obey the safety instructions listed below and take note of appropriate precautions. If you do not, you can cause injury to people and damage to equipment.

- A suitably trained and supervised technician must install your EDP pump.
- Ensure any fluids spilt during top up or re-fill of coolant or oil levels are cleaned up to remove any potential slip hazard.
- Ensure that the installation technician is familiar with the safety procedures which relate to the products pumped. Wear the appropriate safety-clothing when you come into contact with contaminated components. Dismantle and clean contaminated components inside a fume-cupboard.
- Ensure installed cables or pipes do not present a trip hazard.
- Vent and purge the process system before you start installation work.
- Check that all the required components are available and of the correct type before you start work.
- Disconnect the other components in the process system from the electrical supply so that they cannot be operated accidentally.
- Do not reuse O-rings if they are damaged.
- Leak test the system after installation and seal any leaks found, to prevent leakage of hazardous substances out of the system and leakage of air into the system.
- If you will pump substances that may attack or react with the materials of construction of the pump (refer to [Section 2.12](#)), there may be a risk of a leak, or of contamination of the pump oil, or of a loss of pump performance. If you are in any doubt, consult Edwards for advice.
- Consult Edwards Publication P4000000 (Vacuum pump and vacuum system safety - chemical and industrial systems) before you install and use the EDP pump to process hazardous or flammable materials.

3.2 Unpack and inspect



WARNING

Use suitable lifting equipment to move the pump. If you do not, you can injure yourself or damage the pump. Refer to [Section 2.3](#) for the mass of the pump.

1. Use a fork-lift truck or a pallet truck to place the pallet in a convenient position.
2. Remove the packing material from around the pump.
3. Remove small items packed with the pump.
4. Inspect the equipment. If the pump or any of the other items is damaged, notify your supplier and the carrier in writing within three days; state the Item Number of the pump together with your order number and your supplier's invoice number. Retain all packing materials for inspection. Do not use the pump if it is damaged.
5. If the pump is not to be used immediately, replace the packing materials. Store the pump in suitable conditions as described in [Section 6.1](#).

3.3 Locate the pump



WARNING

Use suitable lifting equipment to move the pump. If you do not, you can injure yourself or damage the pump. Refer to [Section 2.3](#) for the mass of the pump.



WARNING

When you move or install the pump, the baseframe of the pump must be no more than 10° from horizontal. If it is, it may topple.



WARNING

Ensure that the cooling-air flow around the pump-motor is not restricted.

Use suitable lifting-equipment to move the pump; use one of the following methods:

- Use the four lifting bolts on the frame ([Figure 1](#), item 5). If you have received a service module, use the four lifting bolts ([Figure 1](#), item 19) on the cartridge.
- On EDP250 and EDP400 pumps, use a fork-lift or pallet truck through the frame lower cross members ([Figure 1](#), items 11 and 24).

Locate the pump on a firm, level surface. Ensure that the surface is clean and free from debris and contamination (such as oil).

Use suitable bolts through the four fixing holes ([Figure 1](#), item 9) to secure the pump in position.

3.4 Check the coolant level

CAUTION

Ensure that you correctly fill the EDP80 and EDP160 pumps with coolant, as described below. If you do not, an air-lock may develop in the cooling-jacket and the pump may overheat.

Note: *Edwards coolant is available as a spare: refer to [Section 7.3](#).*

1. Refer to [Figure 3](#), detail A. Press down the coolant filler-cap (1), turn it anticlockwise and remove it from the pump.
2. Refer to [Figure 3](#), detail A. Remove any dirt or water-scale from the seal of the filler-cap (1) and from the filler-tube (4).
3. Refer to detail B. Check the level of coolant (6); if it is more than approximately 25 mm below the bottom of the filler-neck (5), continue at [Step 4](#), otherwise continue at [Step 10](#).
4. Remove the cap from a new container of coolant. Place a clean funnel into the container and fill the container with clean water.
5. Replace the cap on the container, shake the container to fully mix the water and coolant, then remove the cap.
6. If you have a EDP250 or EDP400 pump continue at [Step 9](#), otherwise continue at [Step 7](#).
7. Refer to [Figure 1](#). Remove the bleed plug (21) from the heat exchanger of the EDP80 or EDP160 pump.

Figure 3 - Fill the pump with coolant

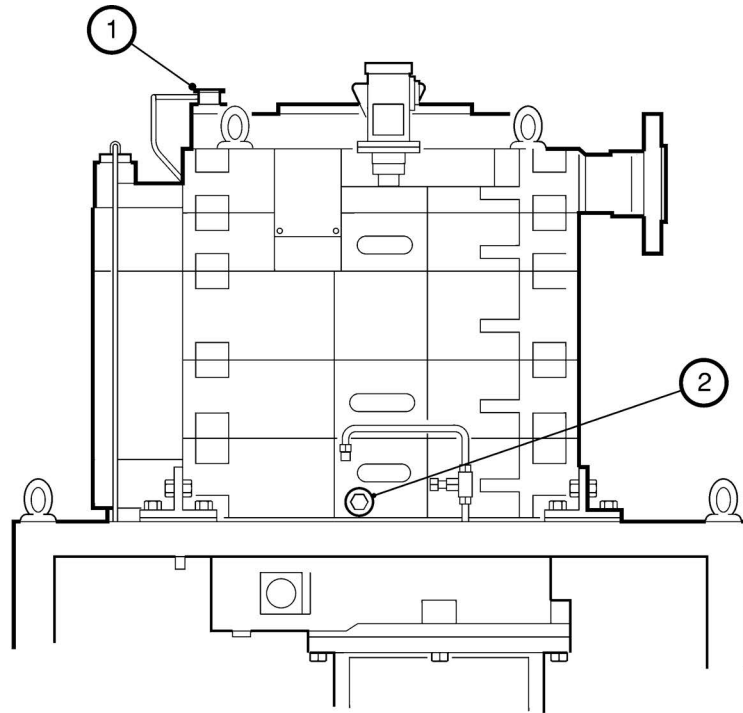

AW/5732/A

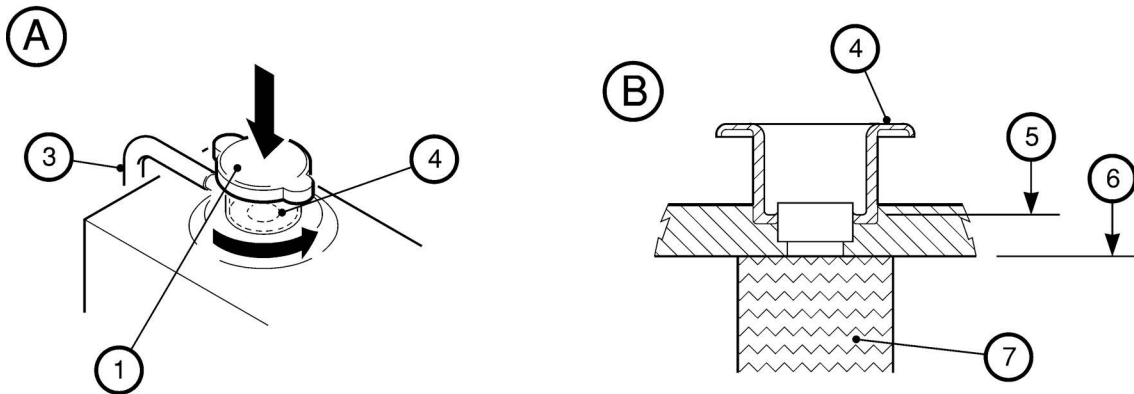

A. Remove the coolant filler-cap

B. Cross section of filler tube

- 1. Coolant filler-cap
- 2. Coolant drain-plug
- 3. Coolant overflow pipe
- 4. Filler-tube
- 5. Bottom of the filler-neck
- 6. Recommended coolant level
- 7. Coolant

8. Refer to [Figure 3](#). Pour the coolant mix into the pump through the filler-tube (4) until coolant leaks from the bleed-port in the heat exchanger, then apply a suitable thread sealant to the threads of the bleed plug ([Figure 1](#), item 21) and refit the bleed plug. If necessary repeat [Step 4 to 8](#) to mix and add more coolant when you pour the coolant mix into the pump.
9. Refer to [Figure 3](#). Pour the coolant mix into the pump through the filler-tube (4) until the coolant level (6) is approximately 25 mm below the bottom of the filler-neck (5). If necessary repeat [Step 4 to 9](#) to mix and add more coolant.
10. Refit the coolant filler-cap (1); press it down and turn it clockwise to secure it to the pump.
11. The coolant overflow pipe is coiled on the frame. Uncoil the coolant overflow pipe and route it to a suitable receptacle or drain.

3.5 Check the gearbox oil-level

The pump is supplied filled with oil. Before you operate the pump, check that the gearbox oil-level is correct. Refer to [Figure 1](#) for the locations of the two oil-level sight-glasses on the pump. The oil-level must be between the MIN and MAX marks on the bezel of either of the two oil-level sight-glasses (see [Figure 6](#), detail A). If necessary, pour more oil into the gearbox: refer to [Section 5.3](#).

3.6 Electrical connections



WARNING

If your EDP pump is part of an ATEX system, refer to the ATEX System instruction manual before you make any of the electrical connections. There may be additional electrical requirements mandated by the ATEX Directive.

3.6.1 Introduction

The installation of this equipment must be performed by skilled technicians who are familiar with this type of industrial vacuum equipment.

Refer to your P&ID to determine which wiring configuration you have and where the interface points are.

Make the electrical connections to the pump as described in the respective manuals.

We recommend that you connect the electrical supply to the pump through a suitable current monitor, and that you configure the high current setting on the current monitor to switch off the pump-motor at a suitable overload current. This overload current must not exceed the maximum current rating shown on the rating plate on the pump-motor.

3.6.2 Connect the electrical supply to the pump-motor



WARNING

Ensure that the electrical installation of the pump conforms to local and national safety requirements. It must be connected to a suitably fused and protected electrical supply and a suitable earth (ground) point.



WARNING

On flameproof pumps, you must use a suitable flameproof cable gland to connect the electrical supply to the pump-motor. If you do not, the installation will not be flameproof.



WARNING

Flameproof pumps must be powered by an electrical supply at the rated frequency of the pump-motor, unless your system is specifically designed to operate with a variable speed drive. If this is the case, consult the ATEX manual (P60060200) and your system manual for details.



WARNING

Install a manual reset device in the pump electrical supply circuit. If not, and a fault condition causes a transient failure of the electrical supply, the pump will automatically switch on again when the electrical supply is restored. If maintenance or fault finding has been started on the pump, there will then be a risk of injury to people.

Connect your electrical supply to the pump-motor through a suitable contactor.

The contactor must incorporate a motor protection circuit-breaker which meets the full load current rating of your motor: refer to the rating plate on the motor and to your motor instruction manual for details.

Connect the electrical supply from the contactor to the pump-motor as described in the Motor instruction manual supplied with your pump.

3.6.3 Connect the pump coolant jacket temperature sensor: introduction

Your EDP pump will be supplied with one of two types of temperature sensor fitted: a temperature transmitter, or a thermal snap-switch.

- If your pump is part of an ATEX system, it will be supplied fitted with a temperature transmitter.
- If your pump is not part of an ATEX system, it may be supplied with either a temperature transmitter or a thermal snap-switch fitted.

Connect the temperature sensor as described in the following sections:

- Refer to [Section 3.6.4](#) if your pump has a thermal snap-switch fitted.
- Refer to [Section 3.6.5](#) if your pump has a temperature transmitter fitted.

3.6.4 Connect the thermal snap-switch (if fitted)



WARNING

Obey the safety instructions given below. If you do not, the installation may not be safe, and there may be a risk of fire or explosion and injury to people.

- You must connect the thermal snap-switch so that the pump stops when the thermal snap-switch opens. If you do not, there may be a risk of fire or explosion.
- Incorporate a manual reset device in your control equipment. If you do not (and a fault which causes the thermal snap-switch to open is not corrected), the pump will automatically switch on again when it cools down. If you have started maintenance or fault finding on the pump, there will then be a risk of fire or explosion and injury to people.
- On flameproof pumps, you must use a suitable M20 x 1.5 ISO flameproof cable gland to connect to the thermal snap-switch. If you do not, the installation will not be flameproof.
- Do not connect the thermal snap-switch into an intrinsically safe circuit if the snap-switch has been previously connected in any other type of circuit. If you do, the contacts in the snap-switch may have been damaged, and the circuit may not be safe.

You **must** connect the thermal snap-switch to the electrical-overload control-loop of your contactor, so that the contactor will automatically switch off the pump if it is too hot.

The thermal snap-switch will reset (that is, close again) when the pump cools down to a preset temperature (see [Section 2.6](#)). We therefore recommend that your control equipment incorporates a manual reset device so that the pump does not automatically switch on again when it cools down.

Refer to the thermal snap-switch instruction manual for wiring details and connection instructions.

3.6.5 Connect the temperature transmitter (if fitted)



WARNING

If the EDP pump is part of an ATEX system, the temperature transmitter must be connected to a suitable control circuit as described below. If it is not, there will be a risk of fire or explosion, or damage to the pump.



WARNING

Install a manual reset device in the pump electrical supply circuit. If not, and the temperature sensor causes the control circuit to shut down the pump, the pump will automatically switch on again when it cools down. If maintenance or fault finding has been started on the pump, there will then be a risk of fire or explosion and injury to people.

CAUTION

Ensure to route the temperature sensor cable away from hot surfaces of the pump or the equipment. If not, the cable may be damaged.

The temperature transmitter provides an indication of the pump coolant jacket temperature.

You must connect the temperature transmitter to a suitable control circuit, to shut down the pump when the coolant jacket temperature reaches an unsafe level:

- We recommend that you configure the control circuit to trip at 15 °C above the pump case operating temperature.

- If the EDP pump is part of an ATEX system, the control circuit trip settings will be defined in the ATEX System instruction manual.

Refer to the temperature transmitter instruction manual for details of how to connect the transmitter to the control circuit.

3.7 Check the direction of pump rotation



WARNING

You must ensure that the direction of rotation of the pump is correct before you operate the pump. If you do not, and the pump direction of rotation is incorrect, the inlet pipeline will be pressurised and may be damaged and there will be a risk of injury to people or explosion or fire.



WARNING

When you check the direction of rotation with the coupling cover guard removed, take suitable precautions to prevent injury from the exposed rotating mechanisms.



WARNING

Refit the coupling cover guard before you operate the pump. If you do not, there will be a danger of injury from the rotating mechanisms of the pump.

1. Refer to [Figure 1](#). Remove the push-on blanking-caps fitted to the pump-inlet (3) and pump-outlet (25).
2. Remove the four bolts which secure the coupling cover guard (14) to the coupling cover (on the opposite side of the pump from the pump-outlet) and remove the coupling cover guard.
3. On pumps with a torque limiter watch the torque limiter plates, and on other pumps watch the coupling hub ([Figure 15](#), item 15), and switch on the pump for one or two seconds, then switch the pump off. Take suitable precautions to prevent injury from the rotating torque limiter/coupling hub when you operate the pump with the coupling cover guard removed.
4. If the torque limiter plates or coupling hub do not rotate in the correct direction (shown by an arrow on the pump-motor, [Figure 1](#), item 10), the direction of rotation is incorrect. If the direction of rotation is incorrect:
 - Isolate the pump from the electrical supply.
 - Reverse any two of the electrical supply phase-wires in the pump-motor terminal-box: refer to the motor instruction manual.
 - Repeat [Step 3](#) and [4](#) to ensure that the direction of rotation is now correct.
5. Refit the coupling cover guard ([Figure 1](#), item 14) and secure with the four bolts. Tighten the bolts to a torque between 3 and 5 Nm.

Figure 4 - Services panel

AW/6261/B

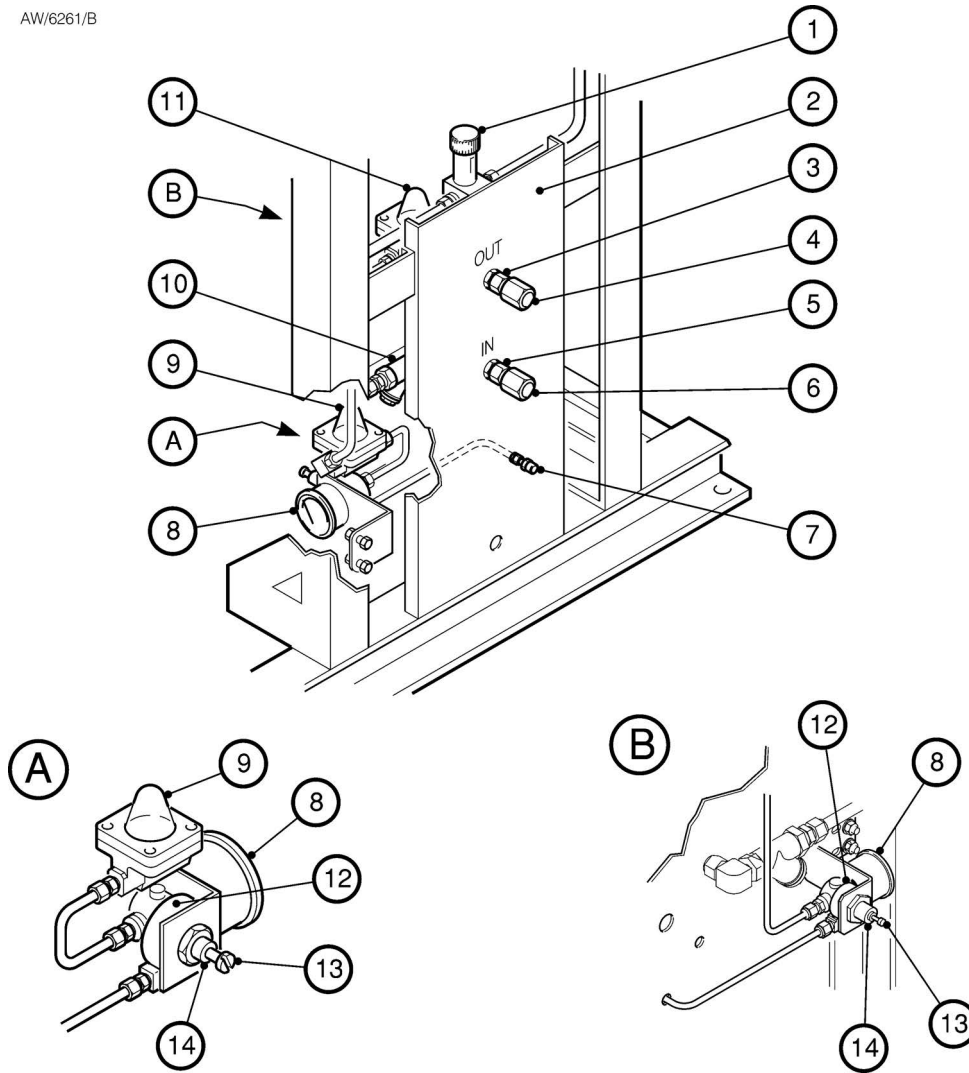

- 1. TCV
- 2. Services panel
- 3. Compression fitting
- 4. Water outlet connector
- 5. Compression fitting
- 6. Water inlet connector
- 7. Nitrogen inlet connector

- 8. Nitrogen pressure gauge
- 9. Nitrogen flow indicator
- 10. Cooling-water filter
- 11. Cooling-water flow indicator
- 12. Nitrogen pressure regulator
- 13. Adjuster
- 14. Locknut

3.8 Connect the cooling-water supply

Refer to [Figure 4](#) and connect the cooling-water supply as described below. If you need to connect more than one EDP pump to the water supply, you must connect them in parallel and not in series.

1. Remove the water inlet and outlet connectors from the fittings kit and fit them onto your cooling-water supply and return pipes.
2. Remove the red blanking caps from the cooling-water inlet and outlet compression connections (5, 3) on the services panel.
3. Fit the pipe fitting (6) on your cooling-water supply pipe to the water inlet compression connection (5) on the water services panel, then tighten the connection.
4. Fit the pipe fitting (4) on your cooling-water return pipe to the water outlet compression connection (3) on the services panel, then tighten the connection.

3.9 Connect the shaft-seals purge nitrogen supply



WARNING

You must ensure that the gas supply to the shaft-seal purge cannot be interrupted during pump operation. Refer to the ATEX manual (P60060200) for further details.



WARNING

Your nitrogen supply pressure must comply with the requirements of [Section 2.6](#). If it does not, the shaft-seals purge pipelines may become over-pressurised and may explode.

Use a rigid metal (such as stainless steel) pipeline with an outside diameter of 1/4 inch for your nitrogen supply.

We recommend that you install an automatically operated isolation-valve in your nitrogen supply pipeline, configured so that:

- The shaft-seals purge nitrogen supply is on whenever the pump is on.
- The shaft-seals purge nitrogen supply is off whenever the pump is off.

Refer to [Figure 4](#) and use the following procedure to connect your shaft-seals purge nitrogen supply:

1. Remove the mating connector from the fittings kit and fit it onto your nitrogen supply pipeline.
2. Remove the red blanking cap from the nitrogen inlet (7) on the services panel and fit the connector on your nitrogen supply pipeline to the nitrogen inlet connector (7).

Figure 5 - Flange loading limits

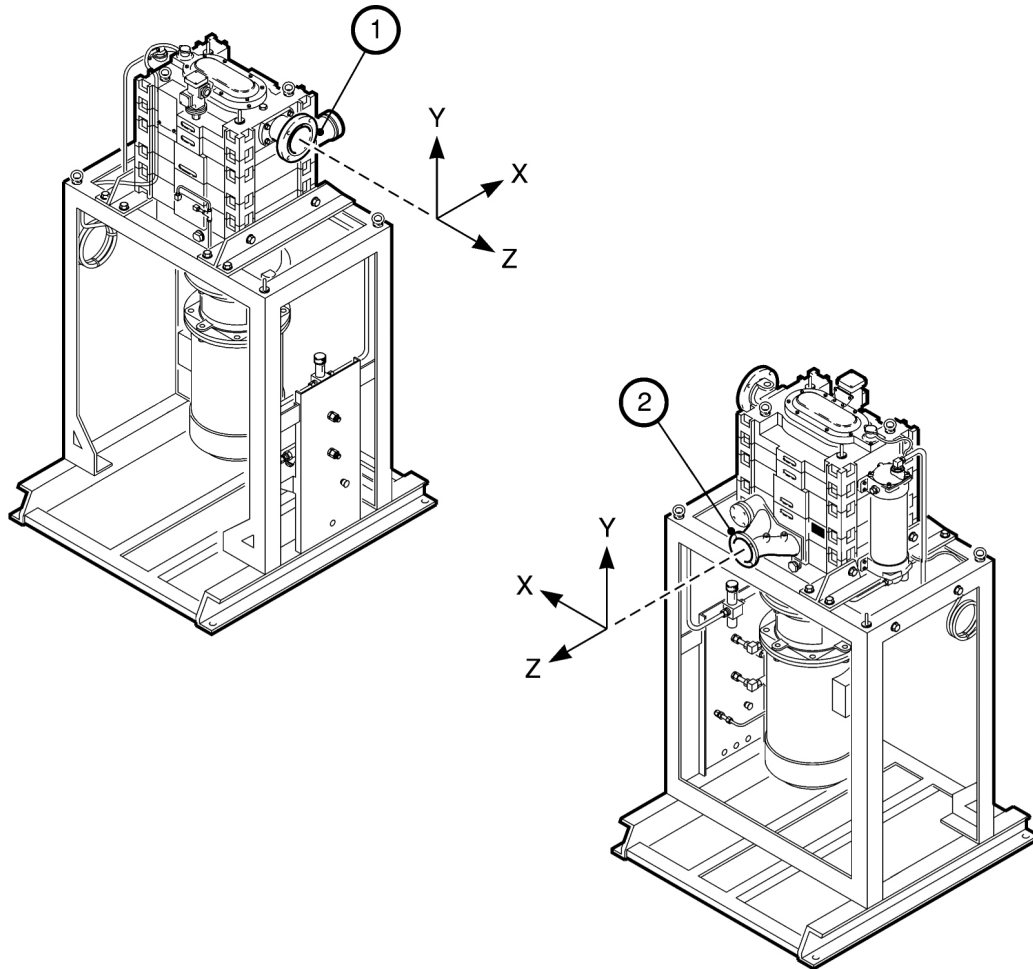

dcsi7284/007

- 1. Pump-inlet
- 2. Pump-outlet

- F. Force
- M. Moment
- R. Resultant
- X. Load orientation
- Y. Load orientation
- Z. Load orientation

Maximum force	Pump-inlet		Pump-outlet		
	FX	±530 N	±120 lbf	±357 N	±80 lbf
FY	±446 N	±100 lbf	±290 N	±65 lbf	
FZ	±669 N	±150 lbf	±446 N	±100 lbf	
FR	±959 N	±215 lbf	±647 N	±145 lbf	
Maximum moment	Pump-inlet		Pump-outlet		
	MX	±476 Nm	±350 lbf ft	231 N m	±170 lbf ft
	MY	±360 Nm	±265 lbf ft	177 N m	±130 lbf ft
	MZ	±238 Nm	±175 lbf ft	115 N m	± 85 lbf ft
	MR	±645 Nm	±475 lbf ft	313 N m	±230 lbf ft

3.10 Connect the pump-inlet and outlet



WARNING

Obey the safety instructions given below. If you do not, the installation may not be safe, and there may be a risk of injury or death to people.

- If your pump is part of an ATEX system, refer to the ATEX System instruction manual if you will pump toxic, flammable or explosive gases.
- Take all necessary safety precautions when you pump toxic, flammable or explosive gases. If you do not, there will be a danger of injury or death to people.
- Ensure that your system can provide adequate gas ballast and/or inlet purge to dilute toxic gases to safe limits. If you do not, there will be a risk of emission of dangerous gases.

3.10.1 Connect the pump-inlet to your process system



WARNING

Do not exceed the load limits on the pump-inlet flange as specified in [Figure 5](#). If you do, there will be a risk of leakage of process gases from the pump, or of damage to the pump.

Note: Flame arrestors suitable for use with the pump are available as accessories: refer to [Section 7.4](#).

When you connect the pump to the process system:

- Support process pipelines to stop the transmission of stress to pipeline joints.
- You must be able to isolate the pump from the atmosphere and from your process system if you have pumped or produced dangerous chemicals.
- Ensure that the loads on the pump-inlet flange do not exceed the limits specified in [Figure 5](#).
- To get the best pumping speed, ensure that the pipeline which connects the process system to the pump is as short as possible and has an internal diameter not less than the pump-inlet.
- Use a flexible connection in the pipeline from the process system to the pump to reduce vibration and stress in the system pipelines.

Use the following procedure to connect the pump-inlet to your process system. Do not allow debris to get into the pump during installation. Refer to [Figure 1](#).

1. The pump-inlet has an inlet filter:

- If you install the pump in a new process system, leave the filter (4) in the pump-inlet (3) to prevent the entry of weld particles or other debris into the pump. You will remove the filter in [Section 5.5](#).
- If you install the pump in an existing process system which you are sure does not contain any debris which could damage the pump, remove the filter (4) from the pump-inlet (3).

2. Use four suitable bolts to connect the pump-inlet to your process system. Use a suitable PTFE gasket to seal the connection. We recommend that you use the gasket type specified in [Section 2.11](#).

3.10.2 Connect the pump-outlet to your exhaust system



WARNING

Pipe the exhaust to a suitable treatment plant to prevent the discharge of dangerous gases or vapours to the surrounding atmosphere.



WARNING

Incorporate safety devices to prevent operation of the pump when the exhaust pipeline is restricted or blocked. If you do not, the exhaust pipeline may become over-pressurised and may burst.



WARNING

Do not exceed the load limits on the pump-outlet flange as specified in [Figure 5](#). If you do, there will be a risk of leakage of process gases from the pump, or of damage to the pump.

CAUTION

Install an outlet catchpot to prevent the drainage of condensate back into the pump. If you do not, condensate which drains back into the pump may damage it or cause it to seize.

Note: Flame arrestors suitable for use with the pump are available as accessories: refer to [Section 7.4](#).

Use four suitable bolts to connect the pump-outlet to your exhaust system. Use a suitable PTFE gasket to seal the connection. We recommend that you use the gasket type specified in [Section 2.11](#).

Your exhaust pipeline system must be designed so that the pressure in the pipeline during pump operation does not exceed the maximum outlet pressure specified in [Section 2.2](#).

Incorporate flexible bellows in the exhaust pipeline to reduce the transmission of vibration and to prevent loading of coupling-joints. If you use flexible bellows, you must ensure that you use bellows which have a maximum pressure rating which is greater than the highest pressure that can be generated in your system.

3.11 Leak test the installation



WARNING

Leak-test the system after installation and seal any leaks found to prevent the leakage of dangerous substances out of the system and leakage of air into the system.

Leak-test the system after installation and seal any leaks found. Substances which leak from the system may be dangerous to people and there may be a danger of explosion if air leaks into the system.

The leak rate of the pump is tested to be less than $(2 \times 10^{-6} \text{ atm ft}^3 \text{ min}^{-1})$ when supplied. The required leak rate for your system will depend on your safety and process requirements.

3.12 Commission the pump

3.12.1 Adjust the thermal snap-switch (if fitted)

Refer to [Figure 1](#). As supplied, the TCV is adjusted so that the pump operating temperature reaches 70 °C measured at the temperature measurement position (27).

If fitted, the thermal snap-switch is adjusted to open when the pump operating temperature reaches 80 °C. This configuration prevents nuisance tripping, but provides protection against operation of the pump when it is too hot.

If you use [Section 3.12.4](#) to adjust the TCV to change the pump operating temperature by a specific amount, we recommend that you adjust the thermal snap-switch by the same amount (in the operating temperature range 50 to 100 °C): refer to the thermal snap-switch instruction manual.

3.12.2 Adjust the pump coolant jacket trip temperature (pumps fitted with a temperature transmitter, if required)



WARNING

If your pump is part of an ATEX system, the temperature trip settings are safety critical, and cannot be altered without the risk of invalidating ATEX certification.

If fitted, the temperature transmitter is configured to provide a signal proportional to the pump coolant jacket temperature.

To change the trip temperature, you must adjust the operation of the control circuit to which the temperature transmitter is connected: make the necessary adjustments to your own control circuit, or refer to the instruction manual supplied, as appropriate.

Note that the nominal setting for the control circuit trip temperature is 15 °C (59 °F) above the nominal pump case operating temperature. However, if the pump is part of an ATEX system, refer to the ATEX manual (P60060200) for the specific safety requirements for the system.

3.12.3 Commissioning procedure



WARNING

If your pump is part of an ATEX system, use the following procedure in conjunction with that described in [Section 7](#) of the ATEX System instruction manual: carry out the checks up to [Step 5](#) below, then use the ATEX control system to switch on the pump.

CAUTION

Do not adjust the TCV to a lower setting (that is, turn the adjuster knob anticlockwise) when the pump is hot. This will increase the flow of cooling-water which may damage the pump because of the differential contraction of the pump rotor and case.

1. Isolate the pump from your process system.
2. Turn on the cooling-water supply, the shaft-seals purge nitrogen supply and your exhaust-extraction system.
3. Check that there are no leaks in the water, nitrogen system, and exhaust-extraction system connections. Seal any leaks found.
4. Refer to [Figure 4](#). Turn the adjuster knob on the TCV (1) to the '0' position. Check that the ball in the cooling-water flow indicator (11) moves; this indicates that there is a flow of cooling-water through the cooling-water flow indicator.

5. Adjust the TCV to the required pump operating temperature; refer to [Table 13](#) for the TCV settings for a pump operating temperature of 65 °C. For a different pump operating temperature, refer to [Section 3.12.4](#).
6. Switch on the pump.
7. Check that the pressure shown on the shaft-seals purge nitrogen pressure gauge (8) is between 0.34 and 0.48 bar, above the exhaust back pressure. If you need to adjust the pressure:
 - Loosen the locknut (14) on the rear of the nitrogen pressure regulator (12).
 - Turn the adjuster (13) until the required pressure is shown on the pressure gauge.
 - Tighten the locknut (14).
8. Leave the pump to operate for approximately 60 minutes to allow the pump operating temperature to stabilise.
9. Check that the pump operating temperature is correct. If necessary, adjust the TCV to change the pump operating temperature (refer to [Section 3.12.4](#)) and adjust the thermal snap-switch or your ATEX control circuit for this new operating temperature (refer to [Section 3.12.1](#) and [3.12.2](#)).
10. Turn off the pump and the cooling-water and shaft-seals purge nitrogen supplies.

3.12.4 Adjust the TCV (thermostatic control-valve)

CAUTION

Do not adjust the TCV to a lower setting (that is, turn the adjuster knob anticlockwise) when the pump is hot. This will increase the flow of cooling-water which may damage the pump because of the differential contraction of the pump rotor and case.

Note: As supplied, the TCV is adjusted for a pump operating temperature of 70 °C (measured at the point shown in [Figure 1](#), item 27). If you adjust the TCV for a different pump operating temperature, you must also adjust the thermal snap-switch (refer to [Section 3.12.1](#)) or the trip temperature of the temperature transmitter control circuit (refer to [Section 3.12.2](#)).
The minimum pump operating temperatures stated in [Table 13](#) are with a cooling-water flow of 12 l min⁻¹ and with a cooling-water supply temperature of 20 °C.

The TCV regulates the flow of water through the water cooling system to maintain the pump at the required operating temperature and is adjustable between 0 (minimum) and 5 (maximum). These TCV settings correspond to the minimum and maximum pump operating temperatures shown in [Table 6](#).

If you need to adjust the TCV to suit your operating conditions, turn the adjuster knob on the TCV ([Figure 4](#), item 1) clockwise or anticlockwise to the position corresponding to your required pump operating temperature. Note that it takes approximately 60 minutes for the pump to stabilise at its final operating temperature.

Table 13 - TCV settings

	EDP80		EDP160		EDP250		EDP400 50 Hz		EDP400 60 Hz	
Minimum pump operating temperature	52 °C	122 °F	50 °C	122 °F	50 °C	122 °F	55 °C	131 °F	55 °C	131 °F
Maximum pump operating temperature	90 °C	194 °F	90 °C	194 °F	90 °C	194 °F	90 °C	194 °F	90 °C	194 °F

Installation

4 Operation

4.1 Operational safety



WARNING

Obey the safety instructions given below. If you do not, the installation may not be safe, and there may be a risk of injury or death to people.

- During operation, parts of the pump can become very hot. Ensure that you do not touch the pump.
- The pump is suitable for handling flammable vapours from Gas Group IIA, IIB and IIC within temperature classifications T1, T2, T3 and T4. Please ensure that suitable flame arresters for the gas group required are fitted when using containment as the protection principle under ATEX. For handling flammable vapours it is necessary to fit additional protective equipment in accordance with the flammable zone that is present inside the pump: for pumps which are part of an ATEX system, refer to the ATEX System instruction manual.
- Do not operate the pump with a coupling cover guard removed. If you do, there will be a danger of injury or death from the rotating mechanisms.
- Do not operate the pump with the pump-inlet or -outlet open to atmosphere. If you do, there will be a danger of injury or death from the rotating mechanisms, from the exposure to vacuum, or from hot exhaust gases.
- On a pump with a torque limiter, do not let the pump-motor operate for more than 8 hours if the torque limiter has tripped and decoupled the pump-motor from the pump. If you do, the torque limiter may get very hot and there may be a risk of fire or explosion.
- You must ensure that the gas supply cannot be interrupted during pump operation. Refer to the ATEX manual (P60060200) for further details.
- If the pump is part of an ATEX system, a pump case temperature limit will have been specified for normal pump operation (refer to the ATEX System instruction manual for details). You must ensure that the pump case temperature is maintained below this limit, otherwise the pump will be switched off by the ATEX control system.

Note: The procedures in the following Sections assume that you have a pump-inlet isolation-valve fitted to your pump.

4.2 ATEX system control

If your pump is part of an ATEX system, use the predefined procedures to:

- Start up the system.
- Allow the pump to warm up.
- Shut down the system.

Refer to the ATEX System instruction manual for details.

4.3 Non-ATEX system control

4.3.1 Start the pump

CAUTION

Allow the pump to warm up before you pump condensable vapours. If you do not, the vapours may condense in the pump and corrode or damage the pump.

If your pump is not part of an ATEX system, use the following procedure to start the pump:

1. Check the gearbox oil-level in the sight-glass on the side of the pump: refer to [Section 3.5](#).
2. Turn on your cooling-water supply, shaft-seals purge nitrogen supply and exhaust-extraction system (if fitted).
3. Check that the pressure of the shaft-seals purge nitrogen supply is correct and adjust if necessary: refer to [Section 3.12.3](#).
4. Switch on the pump.

4.3.2 Allow the pump to warm up



WARNING

During pump warm-up, coolant may drain out of the coolant overflow pipe. Take all necessary precautions if this may present a hazard.

~~This page has been intentionally left blank.~~

CAUTION

Allow the pump to warm up before you pump condensable vapours. If you do not, the vapours may condense in the pump and corrode or damage the pump.

Leave the pump to operate (with the inlet isolation-valve closed) to allow the pump to warm up to its operating temperature, that is, until there is a flow of cooling-water through the heat exchanger:

- Without the inlet purge, warm-up takes approximately 45-60 minutes, depending on the ambient temperature.
- With an inlet purge pressure of 50 to 250 mbar (5×10^3 to 2.5×10^4 Pa, 37.5 to 188 torr), warm-up time can be reduced to as little as 10 minutes.

Refer to [Figure 4](#). When the pump has warmed up to its operating temperature (indicated by a flow of water in the cooling-water flow indicator, 11), you may start process pumping.

In the first 30 seconds of pumpdown, open the inlet isolation-valve slowly if there is liquid in the inlet pipeline, in order to minimize the ingress of liquid (entrained in the process gas stream) into the pump.

4.3.3 Shut down the pump

CAUTION

If the pump is operating in an ambient temperature between -20 and -5 °C, we recommend that the pump is never shut down, other than for maintenance. If you have any doubts about this, please contact Edwards for advice.

CAUTION

Purge the pump before you shut it down. If you do not, process vapours may condense in the pump and corrode or damage it.

Note: If the pump will be shut down for a long time in an environment where the temperature is close to freezing, we recommend that you drain the cooling-water from the pump to prevent damage to the pump: refer to Section 6.1.

1. Isolate the pump-inlet from the process gases.
2. Purge the pump of contaminants. Use one of the following methods:
 - Operate the pump for at least 45 minutes.
 - Operate the pump at or close to atmospheric pressure for at least 15 minutes.
 - Operate the pump with full inlet purge (if fitted) for at least 15 minutes.
 - Operate the pump with full gas ballast (if fitted) for at least 15 minutes.
3. Switch off the pump.
4. When the pump has cooled down, turn off the cooling-water supply and the shaft-seals purge nitrogen supply.

4.4 Inspect and reset the torque limiter (pumps with a torque limiter only)

Refer to the attached amendment for details on operation, inspection and maintenance of the torque limiter or coupling.

WARNING



Switch off the pump and isolate the pump from the electrical supply before you reset the torque limiter. Refit the coupling cover guard before you switch on the pump again. If you do not, there will be a danger of injury or death from the rotating coupling mechanism.

Note: If the torque limiter continually trips and decouples the pump-motor from the pump, refer to Section 5.17.

5 Maintenance

5.1 Safety



WARNING

Obey the safety instructions given below and take note of appropriate precautions. If you do not, you can cause injury to people and damage to equipment.

- Ensure that the ambient atmosphere around the pump is not flammable before you start maintenance.
- A suitably trained and supervised technician must maintain the pump.
- Ensure that the maintenance technician is familiar with the safety procedures which relate to the synthetic oils and greases used and the products pumped. Wear the appropriate safety-clothing when you come into contact with contaminated components, grease and pump oil. Dismantle and clean contaminated components inside a fume-cupboard.
- Use suitable lifting equipment and wear safety shoes when you replace the pump-motor.
- Allow the pump to cool for at least three hours before you start maintenance work.
- Isolate the pump and other components in the process system from the electrical supply so that they cannot be operated accidentally.
- Recheck the pump rotation direction if the electrical supply has been disconnected.
- Do not reuse O-rings or gaskets if they are damaged.
- Protect sealing-faces from damage.
- Do not touch or inhale the thermal breakdown products of fluorinated materials which may be present if the pump has overheated to 260 °C and above. These breakdown products are very dangerous. The pump may have overheated if it was misused, if it malfunctioned, or if it was in a fire. Edwards Material Safety Data Sheets for the fluorinated materials used in the pump are available on request: contact your supplier or Edwards.
- Leak-test the system after installation work is complete and seal any leaks found to prevent leakage of dangerous substances out of the system and leakage of air into the system: refer to [Section 3.11](#).

5.2 Maintenance plan



WARNING

If your EDP pump is part of an ATEX system, you must maintain the pump using the schedule given in [Table 14](#), and as described in [Section 5.3](#) to [5.16](#) of this manual for the ATEX certification to remain valid.

The plan in [Table 14](#) details the maintenance operations required to maintain the pump in normal operation. Instructions for each operation are given in the Section shown. In practice, the frequency of maintenance is dependent on your process. In clean processes, you may be able to decrease the frequency of maintenance operations; in harsh processes you may have to increase the frequency of maintenance operations. Adjust the maintenance plan according to your experience.

When you maintain the pump, use Edwards maintenance and service kits. These contain all of the necessary seals, lubricating grease and other components necessary to complete maintenance operations successfully. The Item Numbers of these kits are given in [Table 18](#).

Table 14 - Maintenance plan

Operation	Frequency	Refer to Section
Check the gearbox oil level and fill the gearbox with oil (if necessary)	Weekly (non-flammable processes) Daily (flammable processes)	5.3
Check the shaft-seals purge supply	Weekly	5.4
Remove the inlet filter	After 1 month of operation	5.5
Inspect the pipelines and connections	3 monthly	5.6
Inspect the pressure relief valve and replace the hinge bushes, flap and 'O' rings (if necessary) *	Yearly or when necessary	5.7
Change the pump oil and clean the oil-level sight-glasses †	Yearly or when contaminated, whichever occurs first ‡	5.8
Relubricate/inspect the rotor bearings †	When necessary **	5.9
Check the coolant level and refill if necessary	Yearly	5.10
Flush the pump with cleaning solution	When necessary	5.11
Clean the cooling system †	Yearly or when necessary	5.12
Overhaul the pump ††	3 yearly	5.13
Replace the pressure relief valve*	When necessary	5.14
Inspect the torque limiter ††	Yearly	5.15
Inspect the torque limiter coupling element	Yearly	
Replace the pump-motor and drive coupling element ***	When necessary	
Fit a replacement service module	When necessary	5.16

* EDP250 and EDP400 only.

† You will need a Routine Maintenance Kit to do these maintenance operations.

‡ If the gearbox oil is contaminated (indicated by a change in colour of the oil, for example, water contamination will turn the oil a white colour), you must change the oil. You may be able to remove the contaminants from the oil by filtration. For maximum pump reliability, we recommend that you change the gearbox oil when you relubricate the rotor bearings: refer to Table 15 in Section 5.9.

** The frequency of maintenance depends on the operating temperature of the pump: see Section 5.9.

†† You must have an Upper Bearing Kit, a Lower Bearing Kit, a Swept Volume Kit and (for the EDP250 and EDP400 only) a Swing Pressure Relief Valve Overhaul Kit to overhaul the pump.

‡‡ Pumps with a torque limiter only.

*** You must have a new pump-motor and a Motor Fitment Kit to do this maintenance operation.

5.3 Check the gearbox oil-level and fill the gearbox with oil (if necessary)



WARNING

The gearbox may be pressurised. To remove the oil filler-plug, undo it slowly until the vent hole is visible, allow the gearbox to vent to atmosphere to reduce the pressure in the gearbox, then fully undo and remove the oil filler-plug. If you do not, hot (up to 90 °C) oil may be ejected under pressure from the gearbox and cause injury.

Note: If you need to pour oil into the gearbox frequently, or if there is a sudden loss of a large amount of oil, this may indicate that the pump has a fault. In these circumstances, we recommend that you shut down the pump as soon as possible and contact your supplier or Edwards for advice.

Figure 1 shows the locations of the two oil-level sight-glasses on the pump. Refer to Figure 6, detail A and check that the pump gearbox oil-level is at the MAX mark on the bezel of either of the two oil-level sight-glasses. If the oil-level is below the MAX mark:

1. Remove the oil filler-plug (3) and bonded seal (2): see Note above.
2. Fit a suitable funnel or nozzle to the oil filler- port (1), then pour oil into the pump gearbox until the oil-level is at the MAX mark on the bezel of the oil-level sight-glass (see detail A).
3. If you overfill the gearbox: place a suitable container under the drain-port (6); unscrew and remove the drain-plug (4) and bonded seal (5) and allow the oil to drain from the gearbox until the oil level reaches the MAX mark on the sight-glass (see detail A), then refit and tighten the drain plug (4) and bonded seal (5).
4. Remove the funnel or nozzle from the oil filler-port (1), then refit the bonded seal (2) and oil filler-plug (3).

5.4 Check the shaft-seals purge supply



WARNING

You must ensure that the gas supply to your shaft-seal purge cannot be interrupted during pump operation. Refer to the ATEX manual (P60060200) for further details.



WARNING

Your nitrogen supply pressure must comply with the requirements of Section 2.6. If it does not, the shaft-seals purge pipelines may become over-pressurised and may explode.

1. Inspect the shaft-seals purge gas supply pipelines and connections; check that they are not corroded or damaged. Replace any pipelines and connections that are corroded or damaged.
2. Check that all of the shaft-seals purge gas supply connections are secure. Tighten any connections that are loose.
3. Check that your purge gas supply can provide the necessary pressure as specified in Section 2.5.

5.5 Remove the inlet filter

If you left the inlet filter in the pump-inlet when you installed the pump (refer to Section 3.10.1), you must remove the inlet filter after the pump has been in operation for one month. If you do not, the performance of the pump will be impaired. Use the following procedure.

1. Disconnect the pump-inlet from your process system.
2. Refer to Figure 1. Remove the inlet filter (4) from the pump-inlet (3).
3. Reconnect the pump-inlet to your process system: refer to Section 3.10.1.

Figure 6 - Oil-level sight-glass and oil filling and draining connections

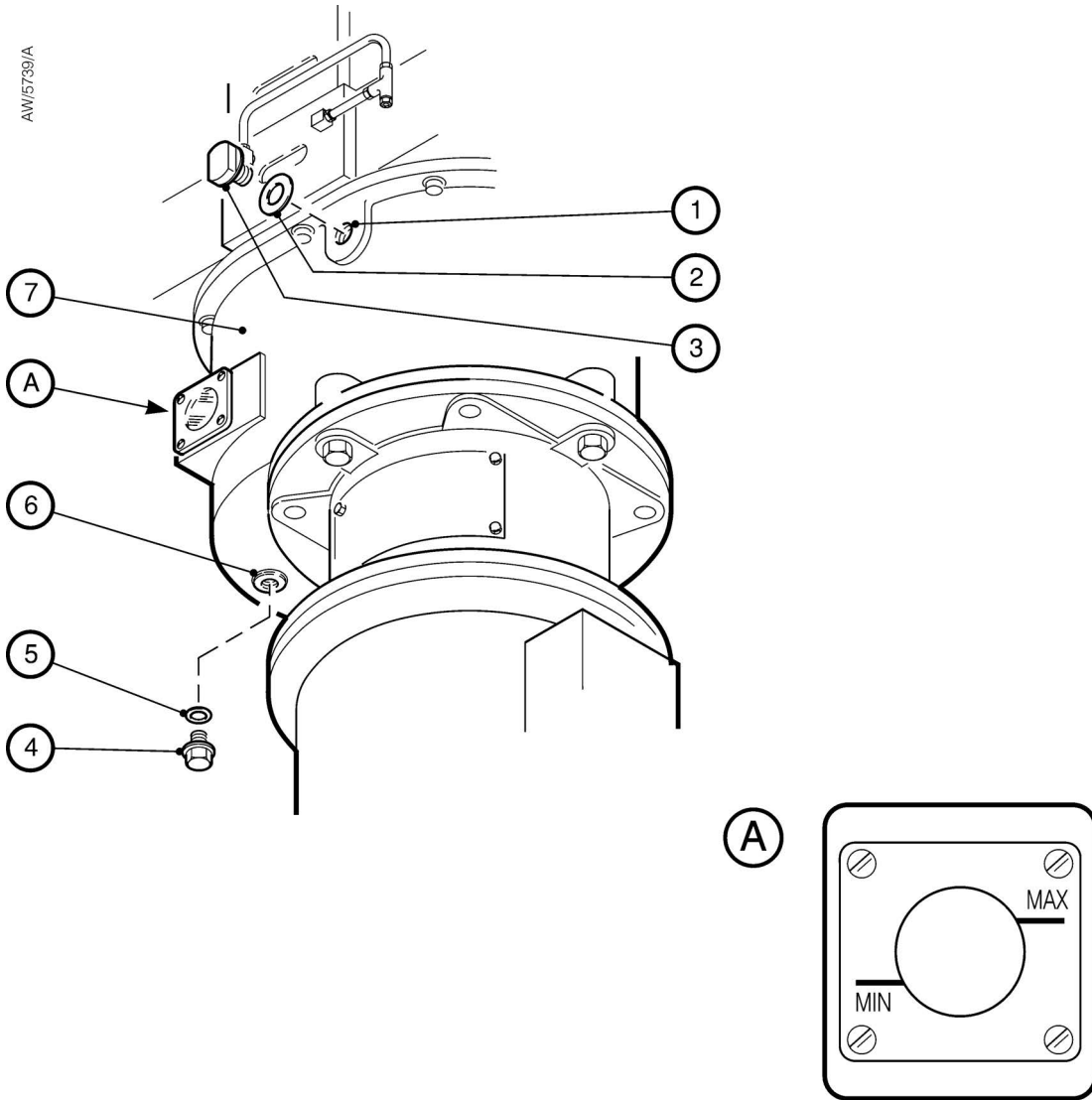

- A. Oil-level sight-glass
- 1. Oil filler-port
- 2. Bonded seal
- 3. Oil filler-plug
- 4. Oil drain-plug (1/2 BSP)
- 5. Bonded seal
- 6. Oil drain-port
- 7. Gearbox

5.6 Inspect the pipelines and connections

1. Inspect all cooling-water pipelines and connections; check that they are not corroded or damaged. Replace any of the pipelines and connections that are corroded or damaged. Check that all cooling-water connections are secure. Tighten any connections that are loose.
2. Inspect all nitrogen supply pipelines and connections; check that they are not corroded or damaged. Replace any pipelines and connections that are corroded or damaged. Check that all nitrogen supply connections are secure. Tighten any connections that are loose.
3. Inspect all electrical cables; check that they are not damaged and have not overheated. Replace any cables that are damaged or have overheated. Check that all electrical connections are secure. Tighten any connections that are loose.
4. Inspect all process and exhaust pipelines; check that they are not corroded or damaged. Replace any pipelines that are corroded or damaged. Check that all process and exhaust connections are secure. Tighten any connections that are loose.

5.7 Inspect the pressure relief valve and replace the hinge bushes, flap and O-ring (if necessary): EDP250 and EDP400 only

If you think that the pressure relief valve does not operate correctly, use the procedures in the following sections to remove, inspect and refit the valve.

5.7.1 Remove the valve from the pump

1. Refer to [Figure 7](#). Remove the four M8 bolts (11) which secure the retainer (9) to the exhaust manifold (3).
2. Fit two of the bolts (11) into the jacking holes (10) and tighten the bolts to remove the retainer (9) from the exhaust manifold (3).
3. Remove the valve flap (7) and the valve body (2) assembly from the exhaust manifold (3).

5.7.2 Clean and inspect the valve



WARNING

If the EDP pump is part of an ATEX system, you must inspect the pressure relief valve in accordance with the following procedure, and replace any components that are damaged, corroded, or do not meet the inspection criteria.

1. Refer to [Figure 7](#). Inspect the valve body (2) and pay special attention to the O-ring grooves. If the valve body or the 'O' ring grooves are corroded, visibly damaged or if there are scratches on the O-ring grooves you must replace the pressure relief valve.
2. Inspect the valve retainer ([Figure 7](#), item 9). If the retainer or the O-ring grooves are corroded, visibly damaged or if there are scratches on the O-ring grooves you must replace the pressure relief valve.
3. Refer to [Figure 7](#). Clean the inside of the exhaust manifold (3) to remove any deposits; if necessary, use a suitable cleaning solution. If you use a cleaning solution, ensure that all of the solution is removed before you fit the new pressure relief valve components.
4. Refer to [Figure 7](#). Inspect the valve flap (7), the hinge bushes (1) and the valve O-ring (6). If any of these items are damaged, you must replace them.
5. Inspect the O-rings (8, 5, 4) and, replace them if necessary.

5.7.3 Refit the valve to the pump

1. Refer to [Figure 7](#). If necessary, refit the two hinge bushes (1) to the valve flap (7), then fit the valve flap to the valve body (2).
2. Refit the valve body (2) in the exhaust manifold (3).
3. Fit the retainer (9) to the exhaust manifold (3) and secure with the four bolts (11). Tighten the bolts to a torque of 10 Nm.

5.7.4 Leak test the pump



WARNING

If your pump is part of an ATEX system, you must leak test the pump after re-fitting the valve to the pump. If you fail to do so, the ATEX certification of your system will be invalid.

5.8 Change the pump oil and clean the oil-level sight-glasses



WARNING

Obey the safety instructions given below and take note of appropriate precautions. If you do not, you can cause injury to people and damage to equipment.

- Changing the oil in a pump from hydrocarbon to PFPE (Fomblin) could potentially cause a safety hazard. Fomblin pumps are generally used in hazardous applications which may involve the pumping of gases with high concentrations of oxygen. If hydrocarbon oil comes into contact with gases with an oxygen concentration greater than 25%, an explosion can occur.
- Therefore, if you want to convert a pump that has been used with hydrocarbon oil to use PFPE (Fomblin) oil, you cannot simply flush the pump with new PFPE oil. You must return the pump to an Edwards Service Centre for overhaul and cleaning by qualified Edwards service engineers. The change in oil type requires a complete strip down of the pump, and thorough cleaning of all parts, so that all traces of hydrocarbon oil are removed.
- Ensure that you do not come into contact with the used pump oil. The gearbox oil may be hot (up to 90 °C) and can cause injury.
- The gearbox may be pressurised. To remove the oil filler-plug, undo it slowly until the vent hole is visible, allow the gearbox to vent to atmosphere to reduce the pressure in the gearbox, then fully undo and remove the oil filler-plug. If you do not, oil may be ejected under pressure from the gearbox.

There are two oil-level sight-glasses on the pump ([Figure 1](#), items 15). You must clean both sight-glasses when you change the gearbox oil.

Figure 7 - Exploded view of the pressure relief valve

AW/4850/B

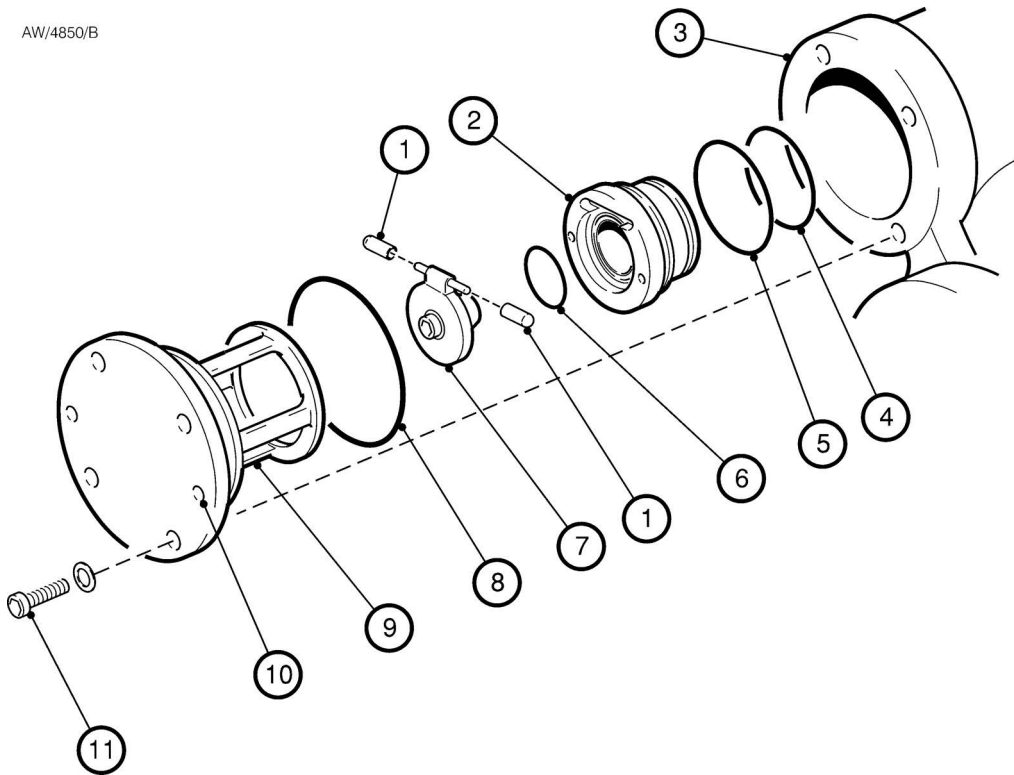

- 1. Hinge bush
- 2. Valve body
- 3. Exhaust manifold
- 4. O-ring
- 5. O-ring
- 6. Valve O-ring
- 7. Valve flap
- 8. O-ring
- 9. Retainer
- 10. Jacking hole
- 11. Bolt (4 off)

1. Refer to [Figure 6](#). Remove the oil filler-plug (3) and bonded seal (2): see Note above.
2. Place a suitable container under the oil drain-port (6); the container must have a capacity of at least 4 litres.
3. Unscrew and remove the oil drain-plug (4) and bonded seal (5) and allow the oil to drain from the gearbox. Dispose of the bonded seal (5).
4. Refer to [Figure 8](#). Undo and remove the four M5 screws (7) from the bezel (6) on one of the oil-level sight-glasses.
5. Remove the bezel (6), O-ring (5), sight-glass (4), O-ring (3) and compression ring (2). Dispose of the O-rings.
6. Clean all of the sight-glass components and the sight-glass recess in the gearbox (1) with a soft lint-free cloth. If necessary, use a suitable cleaning solution; if you use a cleaning solution, ensure that all of the solution is removed before you reassemble the sight-glass.
7. Refit the compression ring (2) in the sight-glass recess in the gearbox (1).
8. Fit two new O-rings (3, 5) and the sight-glass (4), then fit the bezel (6) and secure with the four M5 screws (7).
9. Repeat [Step 4 to 8](#) to clean the other oil-level sight-glass.
10. Refer to [Figure 6](#). Place a suitable funnel or nozzle into the oil filler-port (1).
11. If the oil drained from the pump is very discoloured, flush the gearbox with new or clean oil two or three times, until the oil which drains from the gearbox is clean.
12. Wipe clean the oil drain plug (4), then fit a new bonded rubber seal (5).
13. Fit the oil drain-plug (4) and bonded seal (5) to the drain-port (6).
14. Fill the gearbox through the funnel or nozzle, with the correct grade and quantity of oil. Allow the oil to drain into the gearbox and then check the level on the oil sight-glass (refer to [Section 5.3](#)).
15. Remove the funnel or nozzle from the oil filler-port (1) and refit the oil filler-plug (3) and bonded seal (2) to the oil filler-port (1).
16. Dispose of the used oil safely: refer to [Section 6.2](#).

5.9 Relubricate/inspect the rotor bearings

Note: *If you use the pump on a harsh application, we recommend that an Edwards service engineer removes and cleans the bearing assembly before it is relubricated: contact your supplier or Edwards to arrange this.*

5.9.1 Introduction

The frequency of relubrication of the rotor bearings depends on the operating temperature of the pump. [Table 15](#) shows the recommended frequencies.

For maximum pump reliability, we recommend that you change the gearbox oil when you relubricate the rotor bearings: refer to [Section 5.3](#).

Use the procedures in the following sections to relubricate the rotor bearings.

Table 15 - Recommended rotor bearing relubrication frequencies

Pump operating temperature	Relubrication frequency
up to 70 °C (158 °F)	Every 8800 hours (1 year)
up to 85 °C (185 °F)	Every 4400 hours (6 months)
up to 90 °C (194 °F)	Every 2200 hours (3 months)

5.9.2 Remove the bearing cover and bearing caps



WARNING

Allow the pump to cool down and release the pressure in the cooling jacket before you remove the bearing cover. If you do not, hot coolant may be ejected from the cooling jacket and may cause injury.

1. Refer to [Figure 3](#). Wear thermal protective gloves and push down the coolant filler cap (1) and turn it anticlockwise by a 1/4 of a turn (as shown in detail A) to release the pressure in the cooling jacket.
2. Refer to [Figure 9](#). Remove the ten M10 bolts and spring-washers (15) which secure the bearing cover (5) to the high vacuum head-plate.
3. Remove the M6 screws and nuts which secure the thermal snap-switch to the support bracket.
4. Remove the bearing cover (5), the bearing cover O-ring (14) and the cooling-jacket O-ring (11). Discard the O-rings.
5. Remove the three M8 bearing cap retaining bolts (6) which secure the bearing cap (7) on the drive rotor shaft; ensure that you do not accidentally remove one or more of the bearing carrier bolts (16, see detail A), which are next to the bearing cap retaining bolts. Remove the bearing cap (7) and the bearing cap O-ring (8).
6. Repeat [Step 5](#) to remove the bearing cap (12) and bearing cap O-ring on the driven rotor shaft.

5.9.3 Clean, inspect and relubricate the rotor bearings



WARNING

If the EDP pump is part of an ATEX system, you must inspect the components in accordance with the following procedure, and replace any components that are damaged, or do not meet the inspection criteria.

1. Refer to [Figure 9](#). Use a clean lint-free cloth to remove as much old grease as possible from the inside face of the bearing caps (7, 12) and from the top of the bearings. Do not use your fingers for this operation.
2. Inspect the bearings for obvious signs of wear or the presence of debris. If the bearings are worn, contact your supplier or Edwards for advice.
3. Inspect the O-ring groove on the high vac headplate. Check that the O-ring grooves are continuous, not corroded or have scratches on the surface of the O-ring groove. If the O-ring groove is damaged, contact Edwards for advice; if the pump is part of an ATEX system, do not continue to use the pump.
4. Check the underside of the bearing cover is not damaged. If the underside is damaged and the pump is part of an ATEX system, do not continue to use the pump.
5. Use a suitable syringe to force approximately 50 g of new Fomblin CR861 grease into the bearings so that a smooth layer of grease covers the case and bearings. Do not put too much grease in the bearings or the pump will run hot.
6. Use a 24 mm A/F spanner to turn the drive rotor shaft (9) in the correct direction (13) three or four complete revolutions.
7. Press any grease forced out of the bearings back into the bearings.

Figure 8 - Exploded view of an oil-level sight-glass

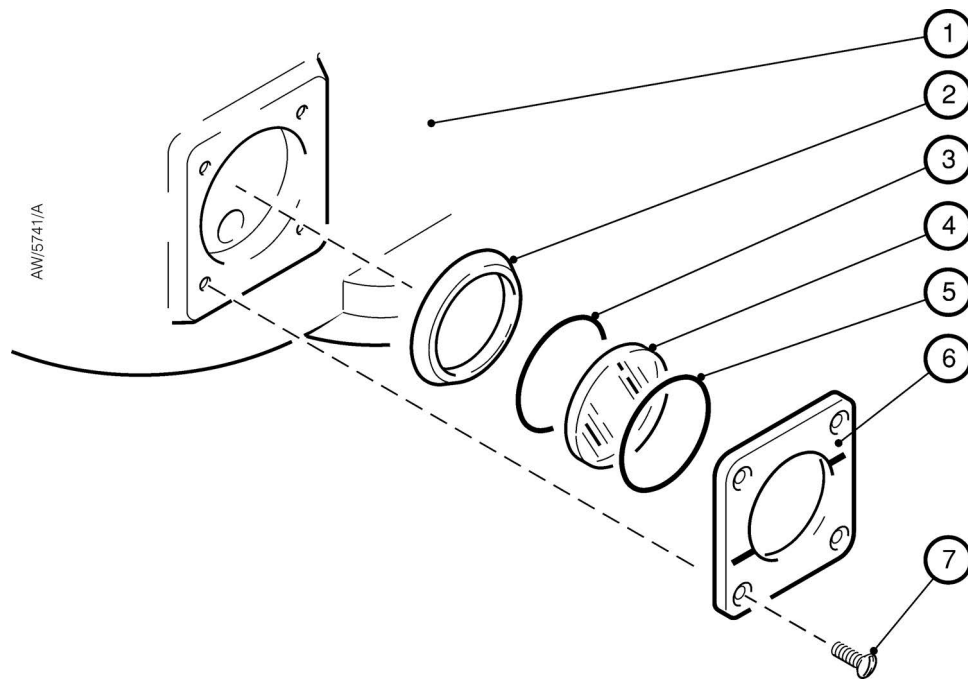

1. Gearbox
2. Compression ring
3. O-ring
4. Sight-glass
5. O-ring
6. Bezel
7. Screw (4 off)

5.9.4 Refit the bearing caps and bearing cover

1. Refer to [Figure 9](#). Refit the bearing cap (7) with a new bearing cap O-ring (8) on the drive rotor shaft. Apply a suitable thread sealant (for example, Loctite Screwlok 242 or equivalent) to each of the three bearing cap retaining bolts (6) and refit the bolts to secure the bearing cap.
2. Repeat [Step 1](#) to refit the bearing cap (12) on the driven rotor shaft.
3. Apply a light wipe of vacuum grease to the new bearing cover O-ring (14) and the water jacket O-ring (11), then place them in position on the high-vacuum head-plate.
4. Refit the bearing cover (5) to the high vacuum head-plate and secure with the ten bolts and spring washers (15).
5. Secure the snap-switch to the support bracket with the two M6 screws (4) and nuts (1).
6. Refer to [Figure 3](#). Turn the coolant filler cap (1) clockwise to tighten it.
7. Dispose of the old grease safely: refer to [Section 6.2](#).

5.9.5 Leak test the pump

If your pump is part of an ATEX system, you must leak test the pump after re-fitting the valve to the pump. If you fail to do so, the ATEX certification of your system will be invalid.

5.10 Check the coolant level and refill if necessary



WARNING

Allow the pump to cool down and release the pressure in the cooling jacket before you remove the coolant filler-cap. If you do not, hot coolant may be ejected from the cooling jacket and may cause injury.



WARNING

Ensure that you correctly fill the EDP80 and EDP160 pumps with coolant, as described in the following sections. If you do not, an air-lock may develop in the cooling-jacket and the pump may overheat.

5.10.1 Refill the pump with Edwards coolant

Note: To refill the pump with Edwards coolant, you will require new coolant, available as a spare: refer to [Section 7.3](#).

1. Refer to [Figure 3](#). Wear thermal protective gloves and push down the coolant filler-cap (1) and turn it anticlockwise by a 1/4 of a turn to release the pressure in the cooling-jacket: see detail A.
2. Remove any dirt or water-scale from the seal of the filler-cap (1) and from the filler-tube (4).
3. Look at the level of coolant (6) in the cooling-jacket. If the coolant level is more than approximately 25 mm below the bottom of the filler-neck (5, see detail B), continue at [Step 4](#), otherwise continue at [Step 5](#).
4. Fill the pump with new Edwards coolant: use the procedure in [Step 4 to 9](#) of [Section 3.4](#).
5. Refit the coolant filler-cap (1); press it down and turn it clockwise to secure it to the pump.

5.10.2 Fill the pump with a different coolant

Note: You will require a Routine Maintenance Kit (see [Section 7.3](#)) to drain and refill the pump with a different coolant.

If you will refill the pump with a different coolant, refer to [Figure 3](#) and use the following procedure. The coolant you use must comply with the requirements of [Section 2.4](#).

1. Refer to [Figure 3](#). Wear thermal protective gloves and push down the coolant filler-cap (1) and turn it anticlockwise by a 1/4 of a turn to release the pressure in the cooling-jacket: see detail A.
2. Turn the coolant filler-cap (1) anticlockwise and remove it from the pump.
3. Remove any dirt or water-scale from the seal of the filler-cap (1) and from the filler-tube (4).
4. If required, place a suitable container under the coolant drain-plug (2), then remove the drain-plug and 1/2 BSP rubber bonded seal from the pump and allow the coolant to drain from the cooling jacket.
5. Flush the cooling-jacket with clean water (through the filler tube) to remove any sludge or debris from the cooling-jacket.
6. Fit the new bonded seal and refit the coolant drain-plug (2) to the pump.
7. Mix the coolant with water as recommended by the coolant manufacturer.
8. Fill the pump with new coolant through the filler tube (4): use the procedure in [Step 4 to 9](#) of [Section 3.4](#).
9. Refit the coolant filler-cap (1); press it down and turn it clockwise to secure it to the pump.

5.10.3 Check for coolant leaks

Check the pump for obvious signs of a coolant leak (for example, a small stream of coolant at one of the joints on the pump-body).

If there are signs of a coolant leak, contact your supplier or Edwards for advice.

5.11 Flush the pump with cleaning solution

5.11.1 Introduction

You must use a cleaning solution suitable for the process substances pumped (refer to the warnings at the start of [Section 5.11.2](#) and [5.11.3](#)). Note that to completely flood all the unblocked cavities in the pump, you will require the quantities of cleaning solution shown in [Table 3](#).

1. Switch on the shaft-seals purge nitrogen supply. If you do not, you will contaminate the lip seals in the pump when you flush it with cleaning solution.
2. Flush the pump:
 - Use the procedure in [Section 5.11.2](#) if you want to remove deposits from a pump which has been operating correctly.
 - Use the procedure in [Section 5.11.3](#) if the pump has seized.

5.11.2 Flush a pump which has been operating



WARNING

Use a cleaning solution which is suitable for the process materials pumped. If you do not, there may be a risk of explosion or pump damage.



WARNING

Ensure that you correctly refit the blanking plugs to the purge ports on the pump. Ensure that the threads in the purge ports are clean and free from damage, and that the plug is undamaged. Replace damaged plugs.

Note: *If the pump has a torque limiter and it has tripped and decoupled the pump-motor from the pump, do not reset the torque limiter (to recouple the pump-motor to the pump) until you have finished this procedure. If you leave the pump-motor decoupled from the pump, it will be easier to turn the pump by hand.*

1. Refer to [Figure 1](#). Remove the four bolts which secure one of the coupling cover guards (14) and remove the guard.
2. Disconnect the exhaust pipeline from the pump-outlet (25) and place a suitable container under the pump-outlet.
3. If you have a pump-inlet isolation-valve in your system, close the valve. If you do not have a pump-inlet isolation-valve, disconnect the pump-inlet (3) from your process system and fit a blanking-flange over the pump-inlet.
4. Refer to [Figure 10](#). Unscrew and remove the blanking plug from the gas ballast purge port (4). Use a suitable tool to inject the cleaning solution into the port until the cleaning solution comes out of the port, then refit the plug to the port.
5. Undo and remove the blanking plug from the middle stage purge port (5). Use a suitable tool to inject the cleaning solution into the port until the cleaning solution comes out of the port, then refit the plug to the port.

Figure 9 - Relubricate the rotor bearings

AW/5742/A

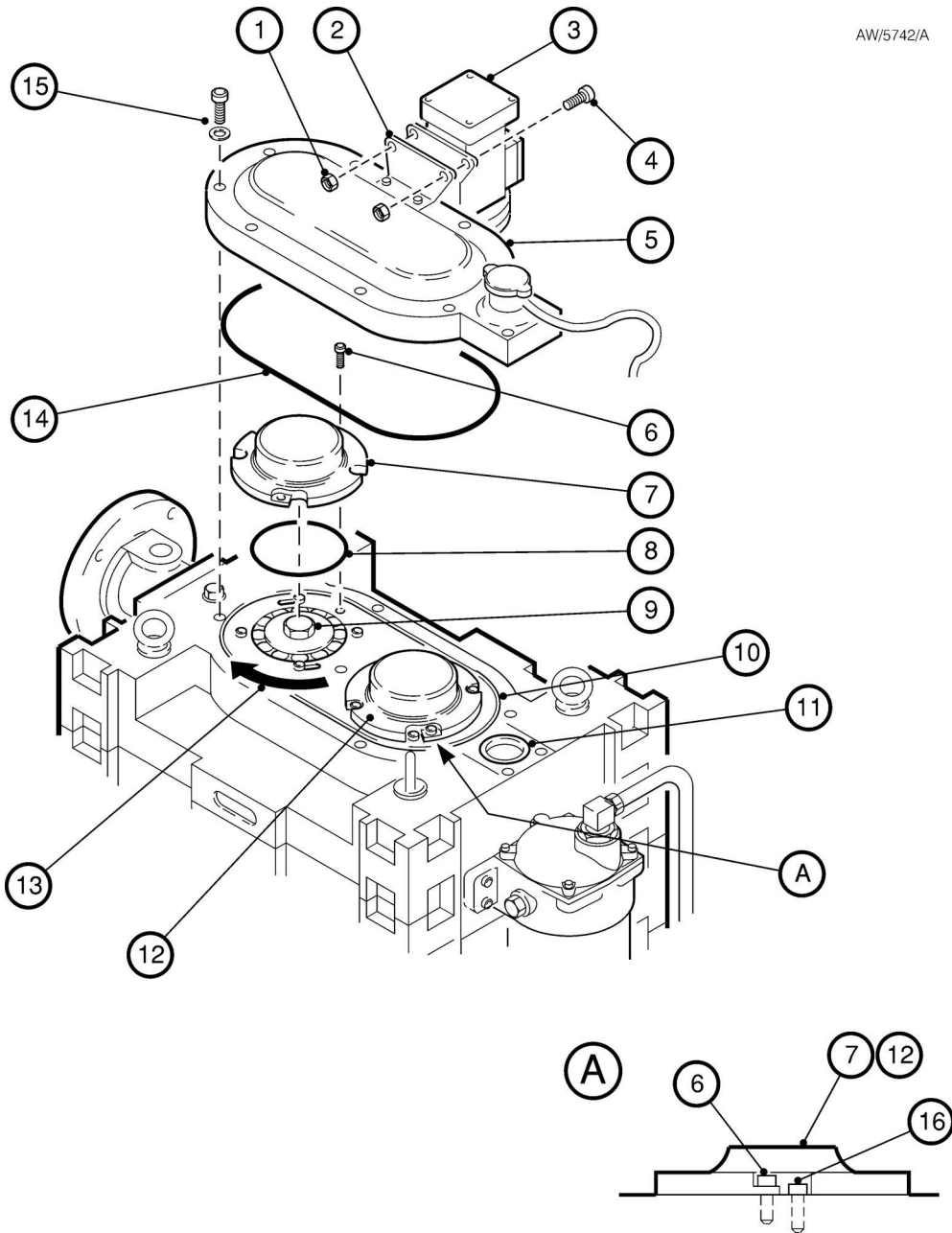

- | | |
|-------------------------------|-----------------------------------|
| 1. M6 nuts | 9. Drive rotor shaft |
| 2. Bracket | 10. Bearing cover O-ring groove |
| 3. Thermal snap-switch | 11. Cooling-jacket O-ring |
| 4. M6 screws | 12. Bearing cap (driven shaft) |
| 5. Bearing cover | 13. Correct direction of rotation |
| 6. Bearing cap retaining bolt | 14. Bearing cover O-ring |
| 7. Bearing cap (drive shaft) | 15. Bolt and spring washer |
| 8. Bearing cap O-ring | 16. Bearing carrier bolt |

6. Remove the plug from the inlet flush port (2), use a suitable tool to inject the cleaning solution into the port until the cleaning solution comes out of the port, then refit the plug.
7. On pumps without a torque limiter, fit a suitable steel rod (not supplied) into the hole in the coupling hub (Figure 15, item 5), then turn the pump clockwise through three or four complete revolutions.
8. Repeat Step 4 to 7 above as necessary, until the pump rotates freely.
9. If you have a pump-inlet isolation-valve, open the valve, otherwise, remove the blanking- flange from the pump-inlet and reconnect the pump-inlet to your process system.
10. Refer to Figure 1. If the pump has a torque limiter and it has tripped and decoupled the pump-motor, reset the torque limiter: refer to attached torque limiter amendment.
11. Use the four bolts to refit the coupling cover guard (14) to the pump. Tighten the bolts to a torque between 3 and 5 Nm.
12. Refit the pump-outlet (25) to your exhaust pipeline, then dispose of the deposits removed from the pump.

5.11.3 Flush a seized pump



WARNING

Use a cleaning solution which is suitable for the process materials pumped. If you do not, there may be a risk of explosion or pump damage.



WARNING

Ensure that you correctly refit the blanking plugs to the purge ports on the pump. Ensure that the threads in the purge ports are clean and free from damage, and that the plug is undamaged. Replace damaged plugs.

Note: *If the pump has a torque limiter and it has decoupled the pump-motor from the pump, do not recouple the pump-motor to the pump until you have finished this procedure. If you leave the pump-motor decoupled from the pump, it will be easier to turn the pump by hand.*

1. Refer to Figure 1. Remove the four bolts which secure one of the coupling cover guards (14) and remove the guard.
2. If you have a pump-inlet isolation-valve in your system, close the valve. If you do not have a pump-inlet isolation-valve, disconnect the pump-inlet (3) from your process system and fit a blanking-flange over the pump-inlet.
3. Refer to Figure 10. Remove the plug from the inlet flush port (2).
4. Disconnect the pump-outlet (3) from your exhaust pipeline and fit a blanking-cap to the pump-outlet.
5. Slowly pour a suitable cleaning solution into the inlet flush port (2). Wait for several minutes to allow the cleaning solution to drain into the pump.
6. Repeat Step 5 until you can pour no more cleaning solution into the pump (see Table 3 for the capacity of the pump), then leave the pump for at least one hour for the cleaning solvent to fully react with the deposits in the pump.
7. On pumps without a torque limiter, fit a suitable steel rod (not supplied) into the coupling hub (Figure 15, item 5), then try to turn the pump clockwise:
 - If you cannot turn the pump, continue at Step 7 (to leave the pump for longer).
 - If you can turn the pump, continue at Step 8.
8. Place a suitable container under the pump-outlet (Figure 10, item 3) and remove the blanking-flange.

9. Use the steel rod to turn the pump clockwise through three or four complete revolutions. If the pump seizes, this is probably because of a hydraulic lock in the pump:
 - Wait for a few seconds for the cleaning solution to drain through the pump, or
 - Remove one or more of the purge port blanking plugs ([Figure 10](#), items 4 and 5) to allow the cleaning solution to drain out of the purge port(s), then refit the plug(s) to the purge port(s).
10. If necessary, repeat [Step 5 to 9](#) to flush the pump again.
11. Remove the blanking-flange from the pump-inlet ([Figure 1](#), item 3) and reconnect the pump-inlet to your process system (refer to [Section 3.10.1](#)) or open the pump-inlet isolation-valve.
12. Reconnect the pump-outlet to your exhaust pipeline: refer to [Section 3.10.2](#).
13. If necessary, recouple the pump-motor to the pump: refer to attached torque limiter amendment.
14. Dispose of the used cleaning solution and deposits removed.

Figure 10 - Flush the pump

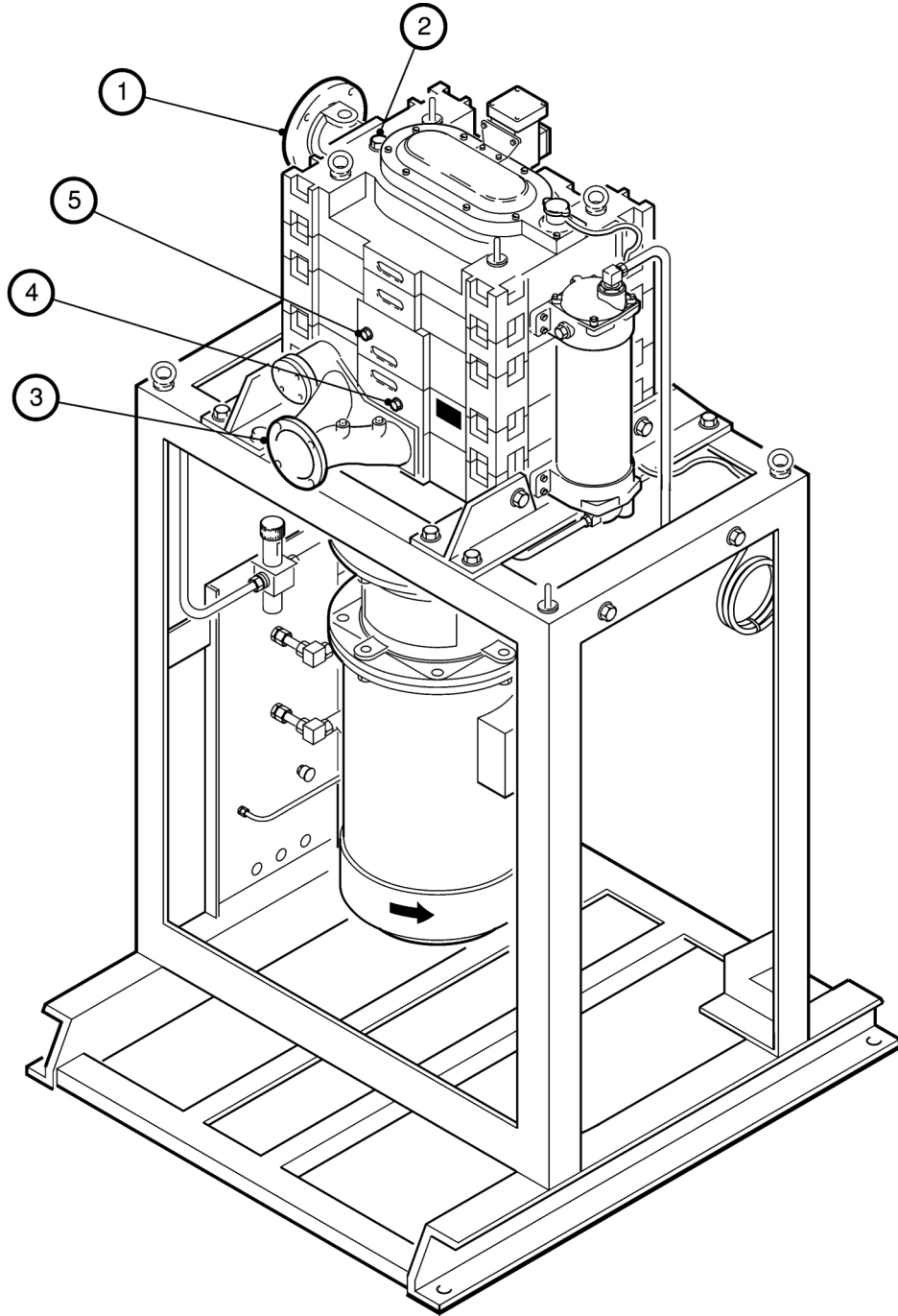

dcs/7284/008

- 1. Pump inlet-flange
- 2. Inlet flush port
- 3. Pump outlet-flange
- 4. Gas ballast purge port
- 5. Middle stage purge port

5.12 Clean the cooling system

5.12.1 Drain the coolant from the cooling system



WARNING

Allow the pump to cool down and release the pressure in the cooling jacket before you remove the coolant filler-cap. If you do not, hot coolant may be ejected from the cooling jacket and may cause injury.

Clean the cooling system every year or when you think that the efficiency of the cooling system is reduced because of deposits or other contamination in the heat exchanger or cooling-water pipelines.

1. Refer to [Figure 1](#). Ensure your cooling-water supply is switched off, then turn the adjuster knob on the TCV (7) to the '0' setting.
2. Refer to [Figure 3](#). Push down the coolant filler-cap (1) and turn it anticlockwise by a 1/4 of a turn to release the pressure in the cooling-jacket: see detail A.
3. Turn the coolant filler-cap (1) anticlockwise and remove it from the pump.
4. Refer to [Figure 4](#). Place a suitable container under the cooling-water connections (3, 5) on the services panel, then remove the connectors (4, 6) on your cooling-water supply and return pipelines from the connections on the services panel and allow the cooling-water to drain from the pump.
5. Drain the coolant from the pump: refer to [Step 3](#) and [4](#) of [Section 5.10.2](#).
6. Refer to [Figure 13](#). Place a suitable container under the drain-plug (7), then remove the drain-plug (7) and allow the cooling-water to drain from the heat exchanger.

5.12.2 Clean the cooling-water filter

The location of the water filter is shown in [Figure 4](#), item 10.

1. Refer to [Figure 11](#). Undo the hex head nut (3) and remove the filter element (4) and the gasket (2) from the cooling-water filter-body (1).
2. Empty the deposits from the filter element (4); if required, you can use a compressed air supply to blow the deposits from the filter element.
3. Fit the new gasket (2) and the cleaned filter element (4) to the cooling-water filter-body (1).

5.12.3 Clean the cooling-water flow indicator

The location of the cooling-water flow indicator is shown in [Figure 4](#), item 11.

1. Refer to [Figure 12](#). Remove the four bolts (1).
2. Remove the bezel (2), gasket (3), dome (4), O-ring (5) and ball (6) from the body of the cooling-water flow indicator.
3. Dispose of the O-ring and the gasket (3).
4. Clean the ball (6), the inside of the dome (4) and the inside of the body (7) to remove any deposits; if necessary, use a suitable cleaning solution.
5. Use the new O-ring and refit the ball (6), O-ring (5), dome (4), gasket (3) and bezel (2) to the body (7) of the cooling-water flow indicator.
6. Use the four bolts (1) to secure the bezel to the body (7) of the cooling-water flow indicator.

Figure 11 - Clean the cooling-water filter

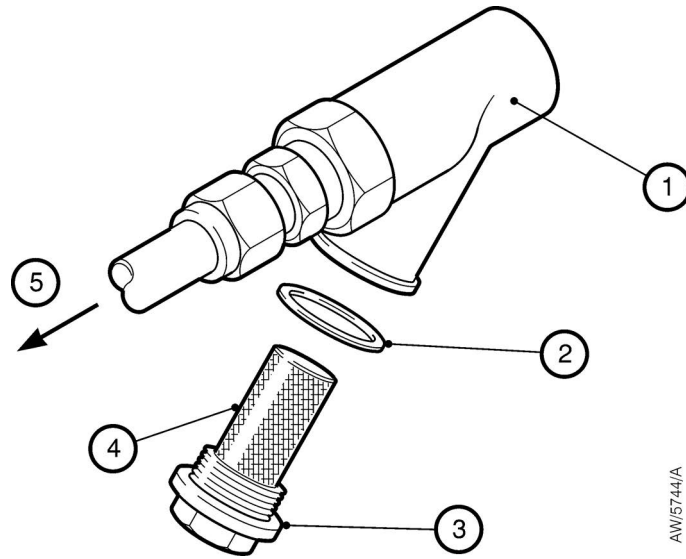

AW/5744/A

- 1. Water filter body
- 2. Gasket
- 3. Hex-head nut
- 4. Filter element
- 5. Direction of cooling-water flow

Figure 12 - Clean the cooling-water flow indicator

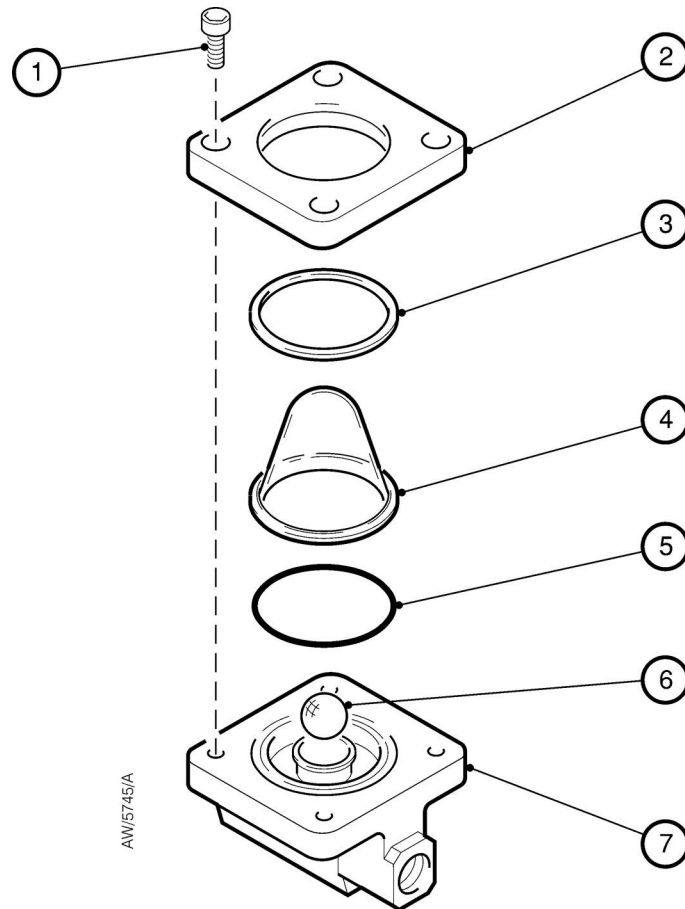

- | | |
|-----------|-----------|
| 1. Bolt | 5. O-ring |
| 2. Bezel | 6. Ball |
| 3. Gasket | 7. Body |
| 4. Dome | |

5.12.4 Clean the heat exchanger

Refer to Figure 13 and use the following procedure to clean the heat exchanger.

1. Undo the fitting nuts (2, 9) of the cooling-water connectors to disconnect the cooling-water pipes from the top and bottom end-caps of the heat exchanger.
2. Remove the four bolts (1) which secure the top end-cap (11) to the heat exchanger and remove the end-cap and the O-ring (10).
3. Remove the four bolts (8) which secure the bottom end-cap (6) to the heat exchanger and remove the end-cap and the O-ring (5).
4. Use a pipe cleaner which will pass through a 400 mm length of 5 mm diameter tube to clean and remove any scale from each tube in the tube stack (3).
5. Clean the O-ring sealing faces of the top and bottom end-caps (11, 6) and the top and bottom of the heat exchanger.
6. Fit the new O-ring (5) and then use the four bolts (8) to refit the bottom end-cap (6) to the heat exchanger.
7. Fit the new O-ring (10) and then use the four bolts (1) to refit the top end-cap (11) to the heat exchanger.

8. Reconnect the fitting nuts (2, 9) of the cooling-water connectors to the top and bottom end-caps (11, 6).

5.12.5 Prepare the pump for operation

1. Refer to [Figure 3](#). Use one of the new rubber bonded seals to refit the coolant drain-plug (2), then refill the pump with coolant: refer to [Step 6 to 8 of Section 5.9.2](#).
2. Refer to [Figure 13](#). Refit the drain-plug (7) to the bottom end cap (6) of the heat exchanger.
3. Refer to [Figure 4](#). Refit the fittings (4, 6) on your cooling-water supply and return pipelines to the connections (3, 5) on the services panel.

5.13 Overhaul the pump

We recommend that the pump is given a major overhaul every three years. If the EDP pump is part of an ATEX system, you **must** give the pump a major overhaul every three years.

Such an overhaul is outside the scope of this manual and should be done by trained customers or by qualified Edwards service personnel only. Please contact your supplier or Edwards for more information.

5.14 Replace the pressure relief valve (EDP250 and EDP400 only)

You must replace the pressure relief valve if it is damaged. The Pressure Relief Valve is available as a spare: refer to [Section 7.3](#).

1. Refer to [Figure 7](#). Undo and remove the four M8 bolts (11) which secure the valve retainer (9) to the exhaust manifold (3).
2. Place two of the bolts in the jacking holes (10) and tighten the bolts to remove the retainer (9) from the exhaust manifold.
3. Remove the O-ring (8), valve flap (7), hinge bushes (1), valve body (2) and O-rings (5, 4) from the exhaust manifold (3).
4. Clean the inside of the exhaust manifold to remove any deposits; if necessary, use a suitable cleaning solution. If you use a cleaning solution, ensure that all of the solution is removed before you fit the new pressure relief valve.
5. Fit the new pressure relief valve to the exhaust manifold and secure with the four M8 bolts (11). Tighten the bolts to a torque of 10 Nm.
6. Leak test the system.

5.15 Inspect the torque limiter

Refer to the attached amendments for details on inspecting the torque limiter or coupling.

5.15.1 Lower the pump-motor and coupling cover (without the motor change frame)



WARNING

Ensure that the pump-motor, motor coupling and coupling cover assembly does not fall over when you move it. If it falls over, it can cause injury to people.

1. Refer to [Figure 14](#) or [15](#). Remove the fixing bolts (11) which secure the coupling cover to the gearbox and lower the pump-motor and coupling cover assembly until the pump-motor rests on the two cross-members at the

bottom of the pump frame (Figure 16, item 4). Ensure that the pump-motor, motor coupling and coupling cover assembly is adequately supported throughout and does not fall over.

2. Continue at Step 13 of Section 5.15.2.

5.15.2 Lower the pump-motor and coupling cover (with the motor change frame)



WARNING

Ensure that the pump-motor, motor coupling and coupling cover assembly does not fall over when you move it. If it falls over, it can cause injury to people.

1. Refer to Figure 16. Undo and remove the three nuts and washers from the tops of the studs (1) and remove the studs and the motor change frame (7) from the pump frame (4).
2. Refer to detail A. Remove the two M16 fixing bolts (8) which secure the coupling cover to the gearbox; one bolt is located next to the oil drain port and the other bolt is on the opposite side of the pump. Do not remove the other two bolts (10), as these secure the pump-motor and coupling cover assembly to the pump.
3. Refer to Figure 14. Loosen the four M16 bolts (9) which secure the coupling cover (12) to the pump-motor (8). Do not over-loosen or remove the bolts, as they secure the pump-motor in place.
4. Refer to Figure 16. Pass the three studs (3) through the holes in the pump frame (4); there are three holes in the pump frame, as follows:
 - Two on the main cross-member, either side of the exhaust manifold.
 - One on the main cross-member on the opposite side of the pump, near the oil filler (refer to Figure 16).
5. Secure the tops of the three studs to the cross-members of the pump frame (4). Use a nut and washer above and below the cross members and ensure that the nuts are tight, so that the studs cannot turn and become detached from the cross-members. The studs should now hang down from the pump frame.
6. Position the motor change frame (6) so that the two locating pins (12, detail B) are upwards.
7. From the oil filler elbow side of the pump, slide the motor change frame between the top and bottom flanges of the coupling cover, as shown in detail B.
8. Refer to detail B. Move the motor change frame (6) up over the studs until the two locating pins (12) fit into the holes (11) from which the two fixing bolts were removed.
9. Hold the motor change frame (6) in place, then fit a washer and nut (5) to the bottom of each stud (3) and spin the nuts upwards until the motor change frame is held tightly in place against the top flange of the coupling cover.
10. Remove the remaining two coupling cover M16 fixing bolts (10). The mass of the pump-motor and coupling cover assembly is now supported by the motor change frame (6).
11. Keep the top of the pump-motor level throughout and undo the three lower nuts (5) on the studs to lower the pump-motor and coupling cover assembly until the pump-motor rests on the two cross-members at the bottom of the pump frame (4). While you undo the three nuts, continually check that the top nuts are tight and that the studs are firmly secured to the pump frame.
12. Ensure that the pump-motor rests securely on the pump frame and remove the motor change frame (6), then remove the three studs (3) from the pump frame.
13. Carefully slide the pump-motor and coupling cover assembly out of the pump frame, then use suitable lifting equipment to lower the pump-motor and coupling cover assembly so that it rests on the floor in an upright orientation (that is, with the top flange of the coupling cover at the top).

5.15.3 Remove the coupling cover from the pump-motor

1. Refer to [Figure 14](#). Remove the four bolts (9) which secure the pump-motor (8) to the coupling cover (12).
2. Take note of the orientation of the coupling cover on the pump-motor (so that you can refit it later in the same orientation), then lift the coupling cover from the pump-motor.

5.15.4 Replace the drive coupling element

Refer to the attached amendment for servicing details.

5.15.5 Remove the drive hub and fit to the new pump-motor (pumps without a torque limiter)

1. Refer to [Figure 15](#). Undo and remove the grub-screw (10) and the grub-screw (14) on the coupling hub (5).
2. Use a suitable puller tool to remove the coupling hub (5) from the motor shaft (6).
3. Remove the key (9) from the shaft and dispose of the key.
4. Dispose of the key supplied with the new pump-motor.
5. Inspect the motor shaft (6) of the new pump-motor (7). The motor shaft must be free of burrs and dirt. If necessary, clean or refinish the motor shaft.
6. Inspect the motor shaft bore of the drive coupling (5). The bore must be free of burrs and dirt. If necessary, clean or refinish the bore.
7. Fit the new key (9, supplied in the Motor Fitment Kit) into the motor shaft (6).
8. Fit the coupling hub (5) onto the motor shaft (6) and push it down until it will go no further. Check that the lower face of the drive hub is 25 mm above the motor flange; if the gap is not correct, contact your supplier or Edwards for advice.
9. Apply a suitable thread sealant (such as Loctite 242 Nutlock) to the new grub-screws (10 and 14), then screw the grub-screws into the correct screw holes in the coupling hub (5). Fully tighten the grub-screws to secure the coupling hub (5) to the motor shaft (6).

5.15.6 Remove the torque limiter and fit to the new pump-motor (pumps with a torque limiter)

1. Refer to [Figure 14](#). Undo and remove the grub-screw (14) and the grub-screw (6) on the torque limiter (5).
2. Use a suitable puller tool to remove the torque limiter (5) from the motor shaft (7).
3. Remove the key (10) from the shaft and dispose of the key.
4. Dispose of the key supplied with the new pump-motor.
5. Inspect the motor shaft (7) of the new pump-motor (8). The motor shaft must be free of burrs and dirt. If necessary, clean or refinish the motor shaft.
6. Inspect the motor shaft bore of the torque limiter (5). The bore must be free of burrs and dirt. If necessary, clean or refinish the bore.
7. Fit the new key (10, supplied in the Motor Fitment Kit) into the motor shaft (7).
8. On the EDP80 pump, fit the torque limiter (5) onto the motor shaft (7) and push it fully down until the lower face of the torque limiter is 24 mm above the motor flange. Refer to attached amendment for details on fitting the torque limiter.

On the EDP160, EDP250 and EDP400 pumps, fit the torque limiter (5) onto the motor shaft (7) and push it fully down until the lower face of the torque limiter is against the shoulder on the motor shaft.

9. Apply a suitable thread sealant (such as Loctite 242 Nutlock) to the new grub-screws (14 and 6), then screw the grub-screws into the correct screw holes in the torque limiter (5). Fully tighten the grub-screws to secure the torque limiter (5) to the motor shaft (7).

Figure 13 - Clean the heat exchanger

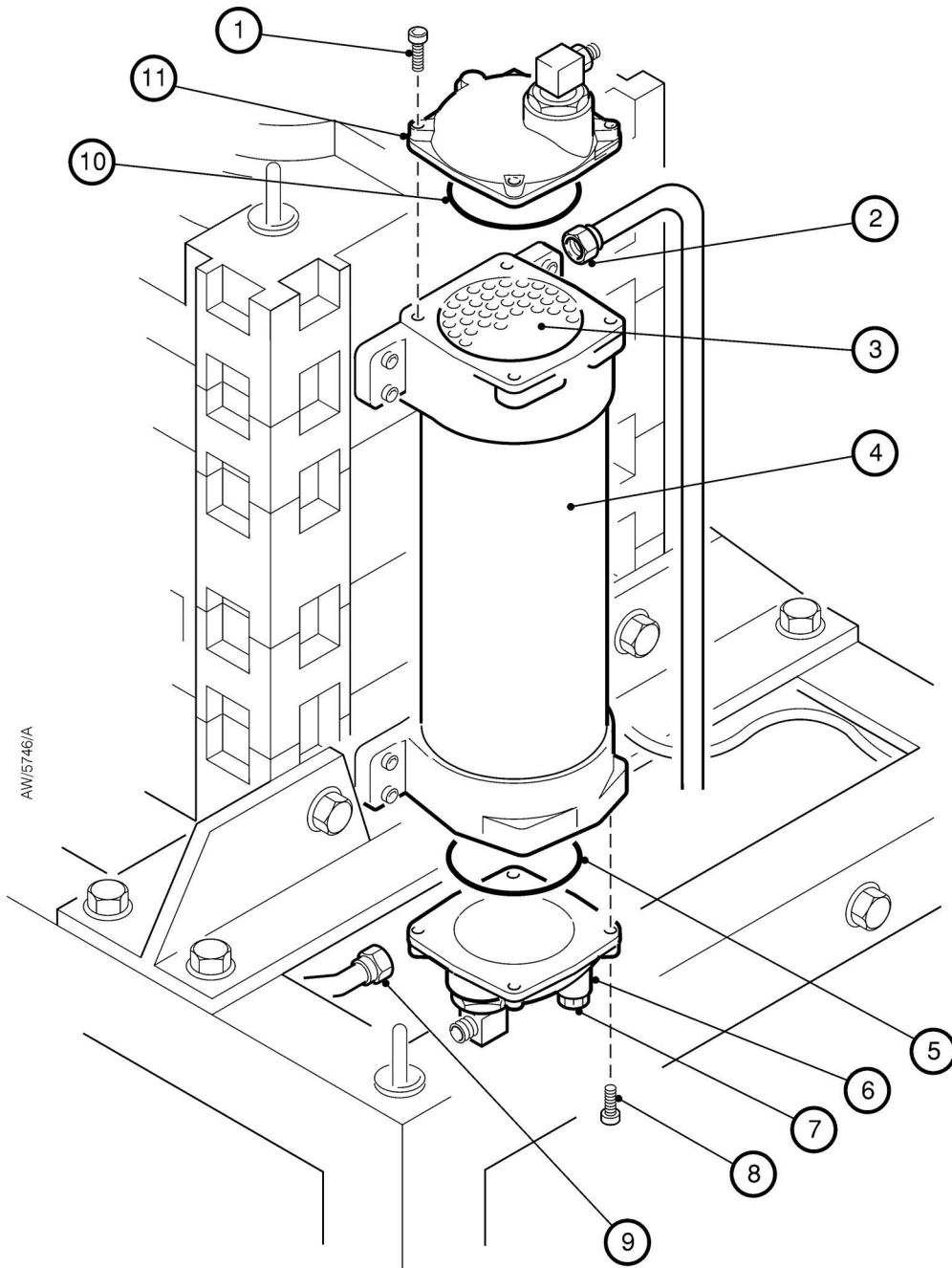

- | | | |
|----------------------------|-------------------|----------------------------|
| 1. Bolt | 5. O-ring | 9. Cooling-water connector |
| 2. Cooling-water connector | 6. Bottom end cap | 10. O-ring |
| 3. Tube stack | 7. Drain-plug | 11. Top end cap |
| 4. Heat exchanger | 8. Bolt | |

5.15.7 Fit the coupling cover to the new pump-motor

CAUTION

Ensure that the pump-motor flange and the bottom flange of the coupling cover are clean and free of burrs. If you do not, the pump-motor and coupling cover may be misaligned and you may damage the pump-motor, the pump or the torque limiter or drive coupling when you operate the pump.

1. Refer to [Figure 14](#). Inspect the bottom flange of the coupling cover (12) and the flange of the pump-motor (8). The flanges must be free of burrs and dirt. If necessary, clean or refinish the flanges.
2. Fit the coupling cover (12) onto the flange of the pump-motor (8). Ensure that the coupling cover is orientated correctly (as noted in [Section 5.15.3](#)): one of the coupling cover guards (2) must be at 90° to the terminal-box on the pump-motor.
3. Fit the four bolts (9) and tighten the bolts to secure the coupling cover (12) to the pump-motor (8); note that you will fully tighten the bolts in [Section 5.15.8](#).

5.15.8 Refit the pump-motor and coupling cover to the pump (without the motor change frame)



WARNING

Ensure that the pump-motor, motor coupling and coupling cover assembly does not fall over when you move it. If it falls over, it can cause injury to people.

CAUTION

Ensure that the bottom flange of the pump gearbox and the top flange of the coupling cover are clean and free of burrs. If you do not, the pump gearbox and coupling cover may be misaligned and you may damage the pump-motor, the pump or the torque limiter or drive coupling when you operate the pump.

1. Refer to [Figure 14](#) or [15](#). Undo and remove the four bolts (3) which secure each of the two coupling cover guards (2) and remove the guard from the coupling cover (12).
2. Inspect the top flange of the coupling cover (12) and the bottom flange of the pump gearbox (1); they must be free of burrs and dirt. If necessary, clean or refinish the flanges.
3. Use suitable lifting equipment to lift the pump-motor and coupling cover onto the bottom of the pump frame. Carefully slide the pump-motor and coupling cover assembly so that it is directly under the pump and so that the pump-motor terminal-box is directly below the gearbox oil drain-plug.
4. Turn the torque limiter or coupling hub (15) until the drive dogs align with the gaps between the drive coupling element in the coupling hub (15).
5. Use the bolts (11) to secure the coupling cover and pump-motor assembly to the pump gearbox (1).
6. Refer to torque limiter or coupling amendment. Check the gap between the bottom face of the coupling hub (15) and the inner faces of the drive dogs. If the gap is correct, continue at [Step 8](#).
7. If the gap is not correct:
 - Check that the bottom flange of the coupling cover (12) is correctly located against the top flange of the pump-motor: refer to [Section 5.15.7](#).
 - Check that the top flange of the coupling cover (12) is correctly located against the bottom flange of the pump gearbox (1): refer to [Step 1 to 7](#) and to the WARNING at the start of this section.

- Check that the drive coupling or torque limiter (5) is correctly located on the motor shaft (7): refer to Section 5.15.5 or 5.15.6.
 - If the coupling cover and the drive coupling or torque limiter are correctly fitted, loosen the two grub-screws (14) on the coupling hub (15) and adjust the position of the coupling, then tighten the two grub-screws (14) again. Continue at Step 8 to check the gap is now set correctly.
8. Ensure that all of the fixing bolts (8, 9 and 11) are tightened to a torque between 128 and 132 Nm.
 9. Use the four bolts (3) to secure each coupling cover guard (2) to the coupling cover. Tighten the bolts to a torque between 3 and 5 Nm.

5.15.9 Refit the pump-motor and coupling cover to the pump (with the motor change frame)



WARNING

Ensure that the pump-motor, motor coupling and coupling cover assembly does not fall over when you move it. If it falls over, it can cause injury to people.

CAUTION

Ensure that the bottom flange of the pump gearbox and the top flange of the coupling cover are clean and free of burrs. If you do not, the pump gearbox and coupling cover may be misaligned and you may damage the pump-motor, the pump or the torque limiter or drive coupling when you operate the pump.

1. Refer to Figure 14 or 15. Undo and remove the four bolts (3) which secure each of the two coupling cover guards (2) and remove the guard from the coupling cover (12).
2. Inspect the top flange of the coupling cover (12) and the bottom flange of the pump gearbox (1). The flanges must be free of burrs and dirt. If necessary, clean or refinish the flanges.
3. Refer to Figure 16. Use suitable lifting equipment to lift the pump-motor and coupling cover onto the bottom of the pump frame (4). Carefully slide the pump-motor and coupling cover assembly so that it is directly under the pump and so that the pump-motor terminal-box (9) is directly below the gearbox oil drain-plug.
4. Refit the three studs (3) to the pump frame (4) and secure with the nuts and washers (2).
5. Fit the motor change frame (6) so that the studs (3) go through the holes in the motor change frame. Slide the motor change frame up the studs until the two locating pins (12) fit in the bolt holes (11) in the top flange of the coupling cover.
6. Hold the motor change frame (6) in place, fit a washer and nut (5) to the bottom of each stud (3) and tighten the nuts up the studs until the motor change frame (6) is secured against the top flange of the coupling cover.
7. Ensure that the top flange of the coupling cover is level at all times and alternately and evenly tighten the three nuts (5) to start to raise the motor change frame (6) and the pump-motor and coupling cover assembly.
8. Refer to Figure 14 or 15. Turn the torque limiter or coupling hub (5) until the drive dogs align with the gaps between the drive coupling element in the coupling hub (15).
9. Refer to Figure 16. Fully tighten the three lower nuts (5) on the studs (3) to raise the pump-motor and coupling cover assembly until the top flange of the coupling cover locates against the bottom flange of the pump gearbox.
10. Use the two M16 bolts (10) to secure the coupling cover and pump-motor assembly to the pump gearbox.
11. Refer to Figure 14 or 15 and torque limiter or coupling amendment. Check the gap between the bottom face of the coupling hub (15) and the inner faces of the drive dogs. If the gap is correct, continue at Step 13.

Figure 14 - Exploded view of the pump-motor, torque limiter and coupling cover (pumps with a torque limiter)

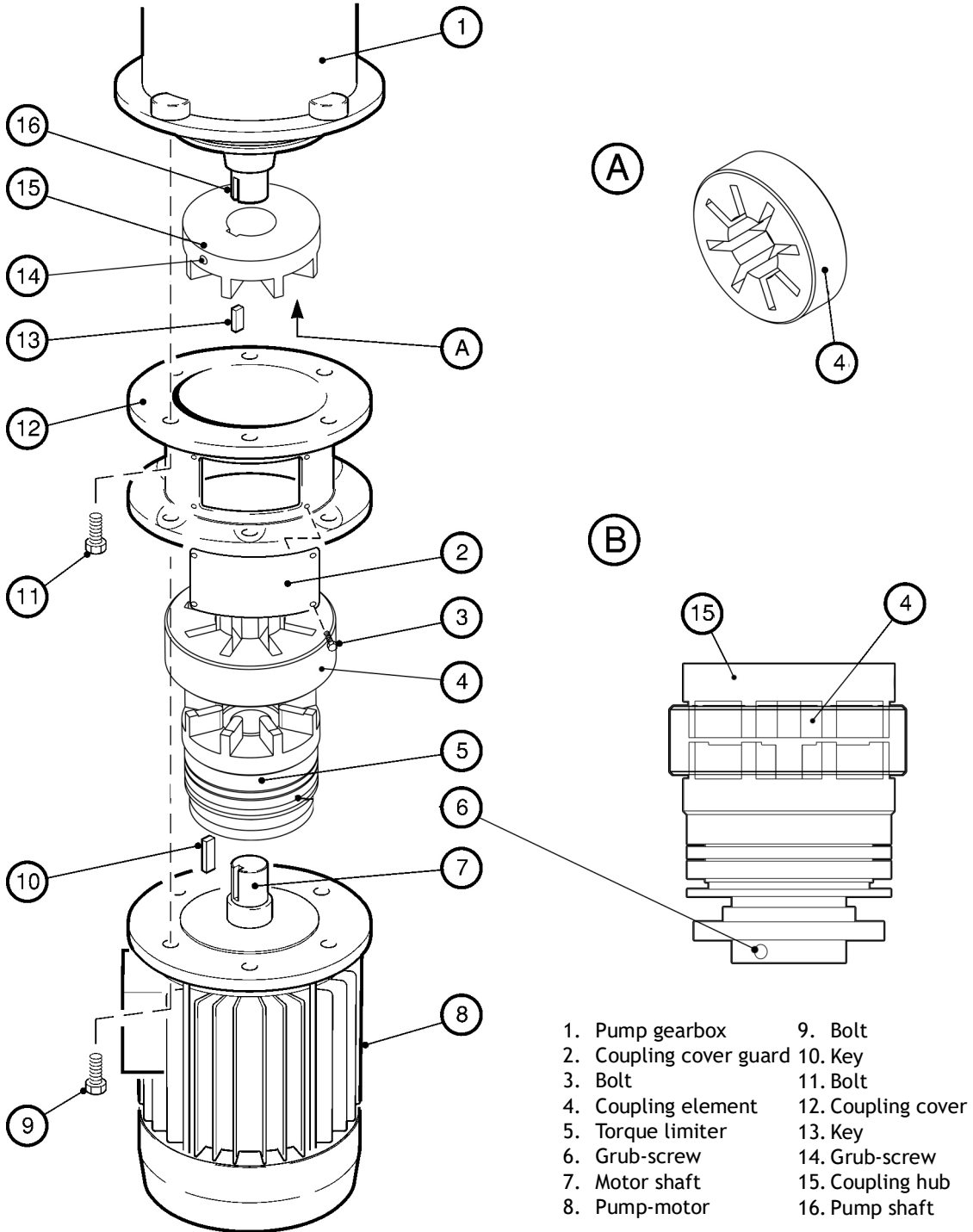

Figure 15 - Exploded view of the pump-motor, coupling drive and coupling cover (pumps without a torque limiter)

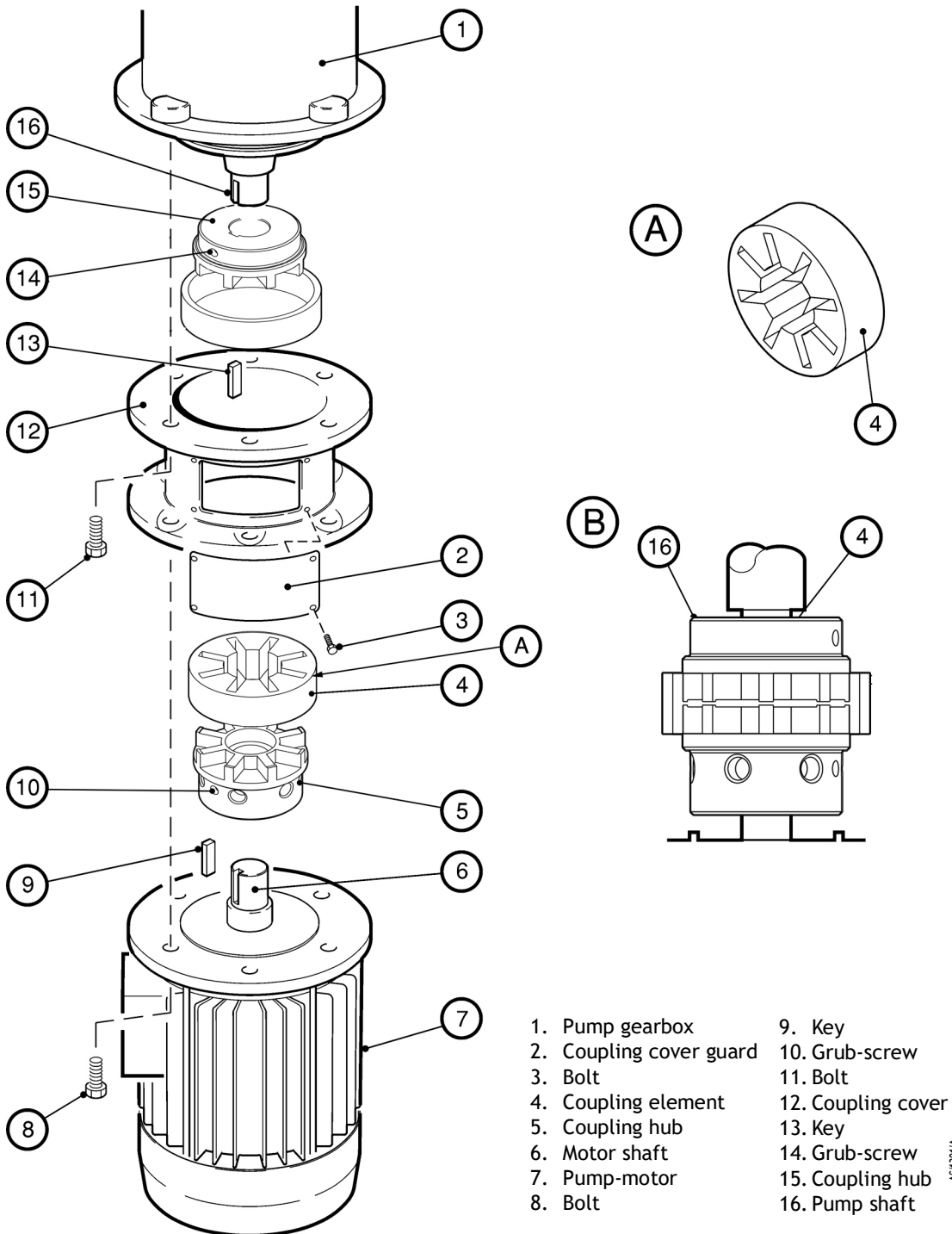
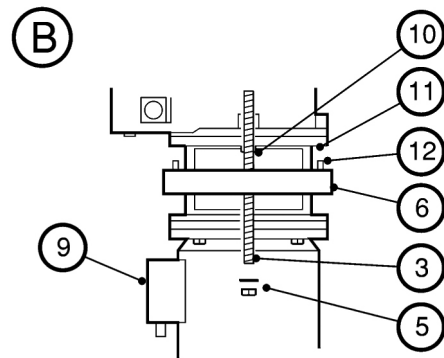
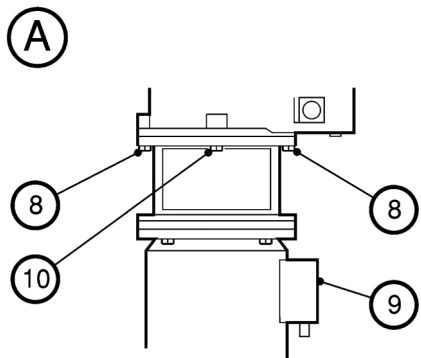
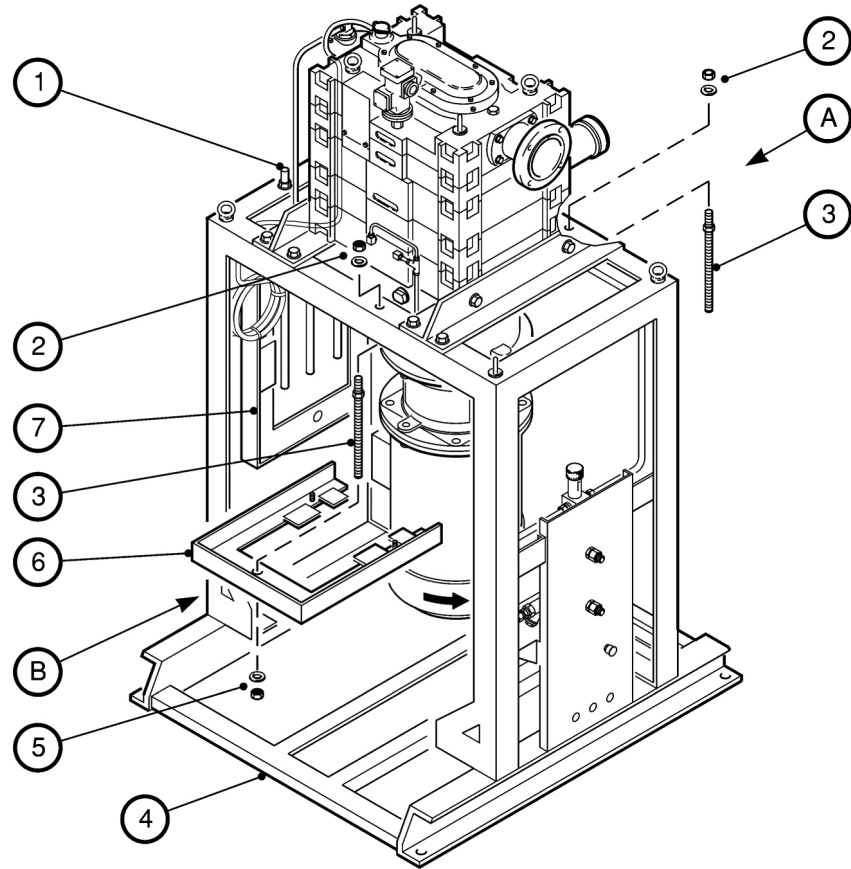

Figure 16 - Use the motor change frame to lower the pump-motor and coupling cover assembly



dcsl7284/012

- | | |
|---|---------------------------------------|
| 1. Stud (on pump frame) | 7. Motor change frame (on pump frame) |
| 2. Nut and washer | 8. Bolt |
| 3. Stud (removed from pump frame) | 9. Pump-motor terminal-box |
| 4. Baseframe | 10. Bolt |
| 5. Nut and washer | 11. Bolt hole |
| 6. Motor change frame (removed from pump frame) | 12. Locating pin |

12. If the gap is not correct:

- Check that the bottom flange of the coupling cover (12) is correctly located against the top flange of the pump-motor: refer to [Section 5.15.7](#).
- Check that the top flange of the coupling cover (12) is correctly located against the bottom flange of the pump gearbox (1): refer to [Step 1 to 10](#) and to the WARNING at the start of this section.
- Check that the torque limiter or coupling hub (5) is located on the motor shaft (6 or 7).
- If the coupling cover and the torque limiter or drive hub are correctly fitted, loosen the two grub-screws (14) on the coupling (15) and adjust the position of the coupling, then tighten the two grub-screws (14) again. Continue at [Step 11](#) to check the gap is now set correctly.

13. Refer to [Figure 16](#). Undo and remove the three nuts and washers (5) from the studs (3) and remove the motor change frame (6) from the studs. Undo and remove the three nuts and washers (2) and remove the three studs (3) from the pump frame (4).

14. Fit the remaining two M16 fixing bolts (8) to fully secure the coupling cover and pump-motor assembly to the pump.

5.16 Fit a replacement service module

5.16.1 Introduction

A service module is a basic pump body without the following components fitted: pump motor, coupling cover, coupling hub, torque limiter (if applicable), inlet adaptor, coolant jacket thermal snap-switch (if applicable), exhaust manifold and pressure relief valve.

To fit a replacement service module to your pump, you must:

- Disconnect your pump from your process and exhaust systems.
- Remove the items listed above from your pump service module, then remove the service module from your pump frame.
- Fit the new (replacement) service module to your pump frame. Inspect the O-ring sealing surface on the inlet adaptor, on the exhaust manifold and the pressure relief valve for damage and scratches. Then fit the items removed from your old pump to the new service module.
- Reconnect the pump to the process and exhaust systems.
- Leak test the pump.



WARNING

If your pump is part of an ATEX system, you must leak test the pump after re-fitting all components to the pump. If you fail to do so, the ATEX certification of your system will be invalid.

Use the procedures in [Section 5.16.2 to 5.16.5](#) to replace a service module.

Note: You must only use the following procedures if you are satisfied that you have the necessary tools and skills required to correctly replace the service module. If you have any doubts, you must contact Edwards or your supplier for advice.

5.16.2 Prepare the pump

1. Shut down the pump and disconnect it from the electrical supply.
2. Refer to [Figure 4](#). Switch off the shaft-seals purge nitrogen supply, then disconnect the nitrogen supply pipeline from the nitrogen inlet (7) on the services panel.
3. Switch off your cooling-water supply, then disconnect your cooling-water supply and return pipelines from the water outlet and inlet connections (3, 5) on the services panel.
4. If the pump has been operating, leave the pump to cool down for at least three hours before you continue at [Section 5.16.3](#).

5.16.3 Remove the old service module



WARNING

Ensure that you wear the appropriate Personal Protective Equipment (PPE) when you remove the service module, if the pump has been used with hazardous process substances.



WARNING

Use suitable lifting equipment to move the service module (pump body). If you do not, you can injure yourself or damage the pump. Refer to [Section 2.3](#) for the mass of the service module.

1. Disconnect the pump-inlet ([Figure 1](#), item 3) from your process system.
2. Refer to [Figure 17](#). Undo and remove the four bolts (2) which secure the inlet adaptor (3), then remove the inlet adaptor from the pump and immediately fit a suitable blanking plug to the inlet port on the pump.
3. Disconnect the pump-outlet ([Figure 1](#), item 25) from your exhaust system.
4. Undo and remove the seven bolts which secure the exhaust manifold (11), then remove the manifold from the pump: ensure that you do not damage the spigot joint between the manifold and pump.
5. Immediately fit a suitable blanking plug to the exhaust outlet port on the pump.
6. Remove the motor and the coupling cover from your pump: refer to [Section 5.15.1](#) and [5.15.2](#).
7. Remove the coupling hub from your pump.
8. Disconnect the shaft-seals purge pipeline (7) from the two elbow fittings (6).
9. Remove the two elbow fittings from the pump, then immediately fit suitable blanking plugs to the shaft seals purge ports on the pump.
10. Remove the TCV sensor capillary stainless steel guard (on the top of the high vacuum plate on the top of the pump, opposite the exhaust outlet). Unscrew the TCV sensor capillary from the brass sensor pocket on the pump, then unscrew the sensor pocket from the pump.

11. If your pump has a coolant jacket thermal snap-switch fitted:
 - Undo the adaptor fitting (9) then remove the thermal snap-switch (10) and support bracket from your pump: if necessary, refer to the thermal snap-switch instruction manual.
 - Remove the adaptor fitting from the pump.
 - Fit a suitable blanking plug to the snap-switch port on the pump.
12. Refer to [Figure 13](#). Remove the heat exchanger:
 - Undo the fitting nuts (2, 9) and disconnect the cooling-water pipes from the top and bottom end caps (11, 6) of the heat exchanger.
 - Undo and remove the eight bolts which secure the heat exchanger (4), then remove the heat exchanger from the pump.
 - Fit suitable blanking plugs to the coolant ports on the pump.
13. Refer to [Figure 17](#). Attach suitable lifting equipment to the lifting bolts (1) on the pump.
14. Undo and remove the four bolts (4) which secure the service module (pump body, 8) to the two frame cross-members (5).
15. Use your lifting equipment to remove the service module (pump body, 8) from the frame.
16. Return the service module to Edwards, or dispose of the service module (refer to [Section 6.2](#)).

5.16.4 Inspect the components removed from the service module



WARNING

If the EDP pump is part of an ATEX system, you must inspect the components in accordance with the following procedure, and replace any components that are damaged, or do not meet the inspection criteria.

Inspect the O-ring sealing surface on the inlet adaptor, on the exhaust manifold and the pressure relief valve for damage and scratches.

5.16.5 Fit the new service module



WARNING

Use suitable lifting equipment to move the service module (pump body). If you do not, you can injure yourself or damage the pump. Refer to [Section 2.3](#) for the mass of the service module.

Use the procedure given below to fit the new service module, and to fit the components removed in [Section 5.16.3](#).

When you fit the new service module, do not refit used O-rings; you must use the new O-rings supplied with the replacement service module (refer to [Table 16](#)).

1. Refer to [Figure 17](#). Attach suitable lifting equipment to the four lifting bolts (1) on the new service module.
2. Use your lifting equipment to lower the service new module (8) into the frame, so that the bolt holes in the service module align with the bolt holes in the two frame cross-members (5).
3. Fit the four bolts (4) to secure the service module (pump body, 8) to the two frame cross-members (5). Tighten the bolts.

4. Refer to [Figure 13](#). Fit the heat exchanger:
 - Remove any blanking plugs from the coolant ports on the pump.
 - Fit the heat exchanger (4) to the pump, and secure with the eight bolts.
 - Connect the fitting nuts (2, 9) on the cooling-water pipes to the top and bottom end caps (11, 6) of the heat exchanger.
5. Refer to [Figure 17](#). If your pump had a coolant jacket thermal snap-switch fitted:
 - Remove any blanking plug from the snap-switch port on the pump.
 - Fit the adaptor fitting (9) to the pump.
 - Fit the thermal snap-switch (10) and support bracket to the new service module and connect with the adaptor fitting (9): if necessary, refer to the thermal snap-switch instruction manual for further information.
6. Screw the brass sensor pocket into the new service module, screw the TCV sensor capillary into the sensor pocket, then fit the TCV sensor stainless steel guard to the service module.
7. Remove any blanking plugs from the shaft seals purge ports on the new service module.
8. Fit the two elbow fittings (6) to the new service module, then connect the shaft-seals purge pipeline (7) to the two elbow fittings.
9. Fit the coupling hub to the service module.
10. Fit the motor and coupling cover to the service module: refer to [Section 5.15.7](#) to [5.15.9](#).
11. Remove any blanking plug from the exhaust outlet port on the new service module.
12. Use the seven bolts to secure the exhaust manifold (11) to the service module. Tighten the bolts.
13. Remove any blanking plug from the inlet port on the new service module.
14. Use the four bolts (2) to secure the inlet adaptor to the new service module. Tighten the bolts.
15. Leak test the system.

WARNING



If your pump is part of an ATEX system, you must leak test the pump after re-fitting the valve to the pump. If you fail to do so, the ATEX certification of your system will be invalid.

After you have fitted the new service module and the pump has passed the leak test, prepare the pump for operation as described in [Section 3](#).

Table 16 - O-rings supplied with the replacement service module

Location	'O' ring size
'O' ring size (mm) Inlet adaptor	74.5 inside diameter x 3.0 section
Exhaust manifold/low vacuum headplate (all pumps)	74.5 inside diameter x 3.0 section
Exhaust manifold/middle stage (EDP250 and EDP400 only)	64.5 inside diameter x 3.0 section
Cooling stack (2 off)	79.5 inside diameter x 3.0 section

Figure 17 - Remove/refit the service module

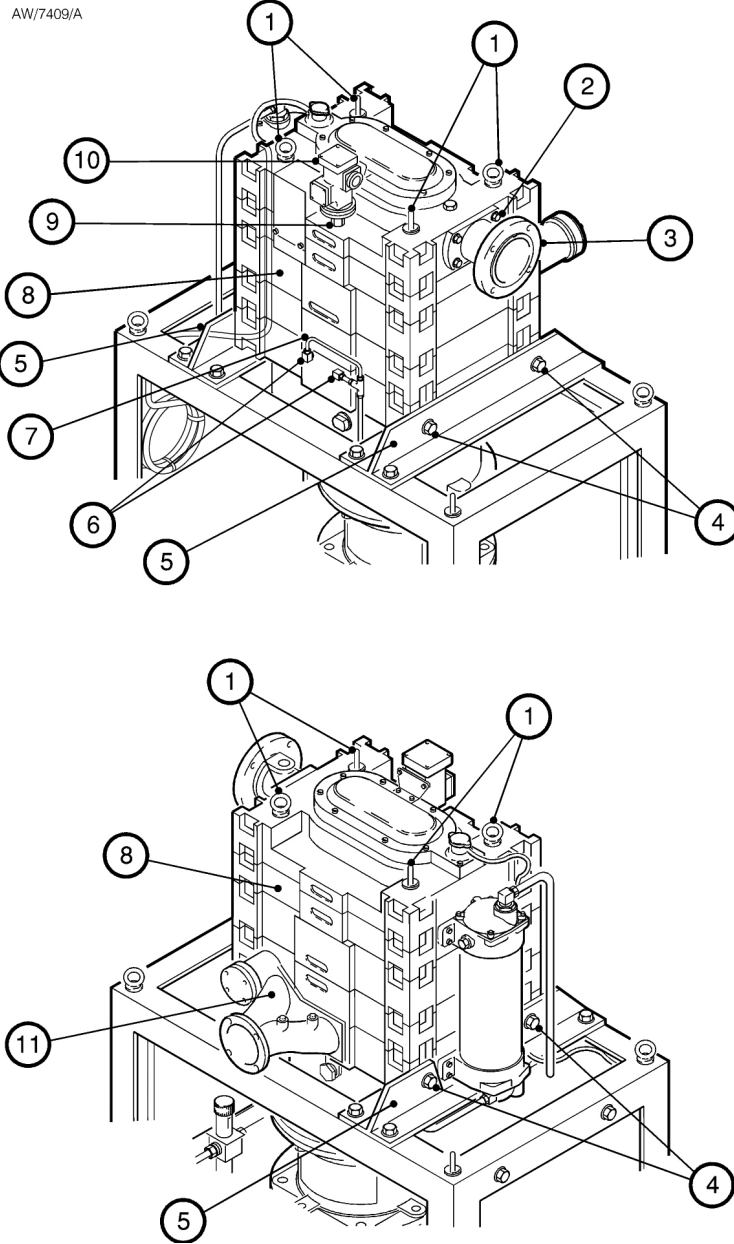

- | | |
|--------------------------------|--|
| 1. Lifting bolts (4 off) | 7. Shaft-seals purge pipeline |
| 2. Bolts (4 off) | 8. Service module (pump body) |
| 3. Inlet adaptor | 9. Adaptor fitting |
| 4. Bolts (4 off) | 10. Coolant jacket thermal snap-switch |
| 5. Frame cross-members (2 off) | 11. Exhaust manifold |
| 6. Elbow fittings | |

5.17 Fault finding

Table 17 - Fault finding

Symptom	Check	Action
The pump-motor starts but the pump does not operate.	Has the torque limiter decoupled the pump-motor from the pump?	Recouple the pump-motor to the pump: refer to Section 4.4 .
The pump suddenly stops or the torque limiter continually decouples the pump-motor from the pump when reset. The pump-motor may be tripping due to excessive electrical current consumption.	Is there a hydraulic lock in the pump?	Switch off and drain the fluid from the pump. If necessary, turn the pump by hand (refer to Step 7 of Section 5.11.3), then recouple the pump-motor to the pump (refer to Section 4.4).
	Has the pump seized due to deposits?	Switch off and then flush the pump (refer to Section 5.10), then recouple the pump-motor to the pump (refer to Section 4.4).
The pump stops but the torque limiter does not decouple the pump-motor from the pump.	Has the thermal snap-switch (if fitted) operated to stop the pump because the pump is operating at too high a temperature?	Check that the thermal snap-switch is correctly set for the required operating temperature. If necessary, adjust the thermal snap-switch (refer to Section 3.12.1).
	Has your ATEX control circuit operated to stop the pump because the pump is operating at too high a temperature?	Check that the temperature transmitter is correctly connected to your control circuit, and that the control circuit is correctly configured: refer to the ATEX System instruction manual.
	Is the TCV incorrectly set?	Check that the TCV is set to the required operating temperature. If necessary, adjust the TCV (refer to Section 3.12.4).
	Is the coolant level too low?	Check that the coolant level in the pump is correct. If necessary, add coolant (refer to Section 5.10).
	Is the heat exchanger blocked?	Check that there is a flow of cooling-water through the heat exchanger: look at the cooling-water flow indicator. If your cooling-water supply is on and is at the correct pressure, the water filter or the heat exchanger may be blocked: clean the cooling system (refer to Section 5.12).
	Has the pump seized because the thermal snap-switch (if fitted) is faulty?	Check the temperature at which the thermal snap-switch operates. If the temperature of the pump-body is > 20 °C above the thermal snap-switch setting, the thermal snap-switch is faulty and you must replace it: contact your supplier or Edwards for advice.

Table 17 - Fault finding (continued)

Symptom	Check	Action
The pump operates at too high a temperature or the pump temperature is unstable. The coolant filler-cap continuously opens to release pressure in the cooling-jacket.	<p>Does the thermal snap-switch (if fitted) not operate at the required temperature?</p> <p>Does the ATEX control circuit not operate at the required temperature?</p> <p>Has the TCV been set correctly?</p> <p>Has the TCV failed?</p>	<p>Check the operation of the thermal snap-switch as described above. Before you restart the pump, check the coolant level (refer to Section 5.10).</p> <p>Check that the ATEX control circuit is correctly configured: refer to the ATEX System instruction manual.</p> <p>Adjust the TCV to a lower temperature setting (refer to Section 3.12.4).</p> <p>If the cooling-water supply is on and is at the correct pressure, but there is no flow indicated in the cooling-water flow indicator, the TCV may have failed: contact your supplier or Edwards for advice.</p>
The pump continues to operate at a high temperature which may result in seizure.	Is the pressure relief valve stuck in the open position?	Inspect the pressure relief valve and clean it or replace it if necessary (refer to Section 5.7 and 5.14).
The pump only achieves an ultimate pump-inlet pressure of 30 to 50 mbar (3×10^3 to 5×10^3 Pa).	Is the pressure relief valve stuck in the open position?	See above.
The pump-motor trips out due to excessive electrical current consumption when the EDP250 pump is operating with pump- inlet pressure in the range 300 to 1000 mbar (3.0×10^4 to 1×10^5 Pa), or when the EDP400 pump is operating with pump- inlet pressure in the range 200 to 1000 mbar (2.0×10^4 to 1×10^5 Pa).	Is the pressure relief valve stuck in the closed position?	See above.
The gearbox and oil are contaminated with the process substances pumped.	<p>Has the shaft-seals purge nitrogen supply failed?</p> <p>Have the seals in the pump failed?</p>	<p>Check that there is a flow of nitrogen purge to the shaft-seals (look at the nitrogen flow indicator); if necessary adjust the pressure regulator (refer to Section 3.12.3). Change the gearbox oil before you restart the pump (refer to Section 5.8).</p> <p>If you cannot adjust the pressure regulator to the required pressure, there is no flow; check your nitrogen supply pressure and rectify as necessary. Change the gearbox oil before you restart the pump (refer to Section 5.8).</p> <p>The seals must be replaced. Contact your supplier or Edwards for advice.</p>
The gearbox is noisy.	Is the oil level low?	Check the oil level and fill as necessary (refer to Section 5.3).

Table 17 - Fault finding (continued)

Symptom	Check	Action
The pump does not operate.	Is the pump-motor faulty?	Make all the other appropriate checks in this table. If there is no other apparent cause for failure of the pump to operate, check the pump-motor and if necessary replace it (refer to Section 5.15).

This page has been intentionally left blank.

6 Storage and disposal

6.1 Storage

Note: *If you will store the pump in an environment with an ambient temperature below - 14 °C, you must also drain the oil and coolant from the pump: use the procedures in Section 5.8 and 5.12.1, then refit all of the drain-plugs to the pump before you store it.*

Store the pump as follows:

1. Ensure that the pump has been shut down as described in Section 4.3.3, then disconnect the pump from the electrical supply.
2. Place a suitable container under the cooling-water connections on the services panel (Figure 4, items 3 and 5), then remove your cooling-water supply and return hoses from the connections and allow the cooling-water to drain from the pump.
3. Drain the cooling-water from the heat exchanger as described in Section 5.12.1. Refit the drain-plug.
4. Disconnect the shaft-seals purge nitrogen supply and disconnect the pump process and exhaust connections.
5. Fit blanking-plates to the pump-inlet and pump-outlet. Place protective covers over the pump services connection points.
6. Store the pump in clean dry conditions until required.
7. If storing pump module for extended periods it is advisable to visually inspect and to manually rotate the pump rotors every 6 months.

When required for use, prepare and install the pump as described in Section 3 of this manual.

6.2 Disposal

Dispose of the pump, cleaning solution, deposits removed from the pump, used pump oil, coolant, grease and any components safely in accordance with all local and national safety and environmental requirements.

Take particular care with the following:

- Fluoroelastomers which may have decomposed as the result of being subjected to high temperatures
- Components and oil which have been contaminated with dangerous process substances.

Storage and disposal

7 Service and spares

7.1 Introduction

Edwards products and spares are available from Edwards companies in Belgium, Brazil, Canada, China, France, Germany, Israel, Italy, Japan, Korea, Singapore, Switzerland, United Kingdom, U.S.A, and a world-wide network of distributors. The majority of these centres employ Service Engineers who have undergone comprehensive Edwards training courses.

Order spare parts from your nearest Edwards company or distributor. When you order, please state for each part required:

- Model and Item Number of your equipment
- Serial number (if any)
- Item Number and description of part.

7.2 Service

Edwards products are supported by a world-wide network of Edwards Service Centres. Each Service Centre offers a wide range of options including: equipment decontamination; service exchange; repair; rebuild and testing to factory specifications. Equipment which has been serviced, repaired or rebuilt is returned with a full warranty.

Your local Service Centre can also provide Edwards engineers to support on-site maintenance, service or repair of your equipment.

For more information about service options, contact your nearest Service Centre or other Edwards company.

7.2.1 Return the equipment or components for service

Before you send your equipment to us for service or for any other reason, you must send us a completed Declaration of Contamination of Vacuum Equipment and Components - Form HS2. The HS2 form tells us if any substances found in the equipment are hazardous, which is important for the safety of our employees and all other people involved in the service of your equipment. The hazard information also lets us select the correct procedures to service your equipment.

We provide instructions for completing the form in the Declaration of Contamination of Vacuum equipment and Components - Procedure HS1.

If you are returning a vacuum pump, note the following:

- If a pump is configured to suit the application, make a record of the configuration before returning the pump. All replacement pumps will be supplied with default factory settings.
- Do not return a pump with accessories fitted. Remove all accessories and retain them for future use.
- The instruction in the returns procedure to drain all fluids does not apply to the lubricant in pump oil reservoirs.

Download the latest documents from www.edwardsvacuum.com/HSForms/, follow the procedure in HS1, fill in the electronic HS2 form, print it, sign it, and return the signed copy to Edwards.

Note: *If we do not receive a completed HS2 form, your equipment cannot be serviced.*

7.3 Spares and maintenance kits

The spare parts and kits listed in Table 18 are available for the EDP pump.

7.4 Accessories

- A number of accessories are available for the EDP pumps, as listed below. Contact your supplier or Edwards for details of these accessories.
- Exhaust Silencers (mild steel or stainless steel)
- Flame arrestors
- Acoustic enclosures and acoustic cover kits
- Gas ballast kits (for standard or flameproof pumps)
- Inlet purge kit (for standard or flameproof pumps)
- Motor change frame.

7.5 Ordering options

If required, you can order a EDP80 or EDP160 pump to be supplied with a torque limiter fitted, instead of the drive coupling: contact your supplier or Edwards.

Table 18 - Spares and maintenance kits

Spare/kit	Item Number
Mobil SHC 629 oil: 1 litre	H11023010
Mobil SHC 629 oil: 4 litres	H11023011
Drystar coolant *	H12810003
Pressure Relief Valve Assembly	A70501832
Routine Maintenance Kit	A70501825
Motor Fitment Kit	A70501805
Upper Bearing Kit	A70501826
Lower Bearing Kit: EDP	A70501828
Swept Volume Kit	A70501827
O-Ring Kit	A70501821
Swing Pressure Relief Valve Overhaul Kit	A70501833
Grease CR861	H11350116
Service module	
EDP80	A70545008
EDP160	A70544008
EDP250	A70543008
EDP400 (50 Hz)	A70542008
EDP400 (60 Hz)	A70541008

* 0.9 l as supplied, 2.0 l when diluted

Index

A

Abnormal operation 8
 Accessories 7, 76
 Adjust the pump coolant jacket trip temperature (pumps fitted with a temperature transmitter, if required) 30
 Adjust the TCV (thermostatic control-valve) 31
 Adjust the thermal snap-switch (if fitted) 30
 Allow the pump to warm up 34
 ATEX system control 33

C

Change the pump oil and clean the oil-level sight-glasses 42
 Check for coolant leaks 48
 Check the coolant level and refill if necessary 47
 Check the direction of pump rotation 24
 Check the gearbox oil-level 20
 Check the gearbox oil-level and fill the gearbox with oil (if necessary) 38
 Check the shaft-seals purge supply 39
 Clean the cooling system 53
 Clean the cooling-water filter 53
 Clean the cooling-water flow indicator 53
 Clean the heat exchanger 55
 Clean, inspect and relubricate the rotor bearings 45
 Commissioning the pump 30
 Commissioning procedure 30
 Connect the cooling-water supply 26
 Connect the electrical supply to the pump-motor 21
 Connect the pump coolant jacket temperature sensor introduction 21
 Connect the pump-inlet and outlet 28
 Connect the pump-inlet to your process system 28
 Connect the pump-outlet to your exhaust system 29
 Connect the shaft-seals purge nitrogen supply 26
 Connect the temperature transmitter (if fitted) 22
 Connect the thermal snap-switch (if fitted) 22
 Connections 13
 Cooling-water data 11

D

Disposal 73
 Drain the coolant from the cooling system 53
 Drive coupling operation 3
 Drive operation 3

E

Electrical connections 20
 Electrical data 10

F

Fault finding 70

Fill the pump with a different coolant 47
 Fit a replacement service module 65
 Fit the coupling cover to the new pump-motor 60
 Fit the new service module 67
 Flush a pump which has been operating 48
 Flush a seized pump 50
 Flush the pump with cleaning solution 48

H

Hazardous area and safe area versions of the pump 7

I

Inspect and reset the torque limiter (pumps with a torque limiter only) 35
 Inspect the components removed from the service module 67
 Inspect the pipelines and connections 41
 Inspect the pressure relief valve and replace the hinge bushes, flap and O-ring (if necessary)
 EDP250 and EDP400 only 41
 Inspect the torque limiter 56
 Installation 17

L

Leak test the installation 29
 Leak test the pump 42, 46
 Locate the pump 18
 Lower the pump-motor and coupling cover (with the motor change frame) 57
 Lower the pump-motor and coupling cover (without the motor change frame) 56
 Lubrication data 12

M

Maintenance 37
 Maintenance plan 37
 Materials of construction 16
 Mechanical data 10

N

Noise data 13
 Non-ATEX system control 34
 Normal operation 7

O

Operating and storage conditions 9
 Operation 33
 Operational safety 33
 Ordering options 7, 76
 Overhaul the pump 56

P

Performance	9
Prepare the pump	66
Prepare the pump for operation	56
Pressure relief valve (EDP250 and EDP400 only)	3
Pump frame	4
Pump motor applicability	7

R

Refill the pump with Edwards coolant	47
Refit the bearing caps and bearing cover	46
Refit the pump-motor and coupling cover to the pump (with the motor change frame)	61
Refit the pump-motor and coupling cover to the pump (without the motor change frame)	60
Refit the valve to the pump	42
Relubricate/inspect the rotor bearings	44
Remove the bearing cover and bearing caps	45
Remove the coupling cover from the pump-motor ..	58
Remove the drive hub and fit to the new pump-motor (pumps without a torque limiter)	58
Remove the inlet filter	39
Remove the old service module	66
Remove the torque limiter and fit to the new pump- motor (pumps with a torque limiter)	58
Remove the valve from the pump	41
Replace the drive coupling element	58
Replace the pressure relief valve (EDP250 and EDP400 only)	56

S

Safety	17
Scope and definitions	1
Service	75
Shaft-seals purge	2
Shaft-seals purge nitrogen supply data	10
Shut down the pump	35
Spares and maintenance kits	76
Start the pump	34
Storage	73

T

Technical data	9
Temperature control system	2
The EDP pumps	1
Torque limiter operation	3

U

Unpack and inspect	17
--------------------------	----

EU Declaration of Conformity

**Edwards Ltd**

Innovation Drive
Burgess Hill
West Sussex
RH15 9TW
UK

Documentation Officer

Jana Sigmunda 300
Lutín , 78349
Czech Republic
T: +42(0) 580 582 728
documentation@edwardsvacuum.com

The product specified and listed below

Product: Drystar Bareshaft Pumps

Models: EDP80, EDP160, EDP250, EDP400

Product Numbers:	EDP80 50Hz	A70545000	EDP250 50/60Hz	A70543000
	EDP80 60Hz	A70547000	EDP400 50Hz	A70542000
	EDP160 50Hz	A70544000	EDP400 60Hz	A70541000
	EDP160 60Hz	A70546000		

Is in conformity with the relevant requirements of European CE legislation:

- 2006/42/EC Machinery directive
Note: The safety objectives of the Low Voltage Directive 2014/35/EU were complied with in accordance with Annex 1 No. 1.5.1 of this directive.
- 2014/34/EU ATEX directive on use in potentially explosive atmospheres
Internal Ex II 1 G Ex h IIB3 T4 Ga
External Ex II 2 G Ex h IIC T4 Gb
INTERTEK Italia S.p.A. NB 2575
ITS03ATEX11396X
Maximum process temperature of +60 °C for high mass flow/ above 100 mbar conditions and +85 °C for low mass flow/ below 100 bar conditions
Ambient temperature is T amb -15 °C to 40 °C
- 2011/65/EU Restriction of certain hazardous substances (RoHS) directive
as amended by Delegated Directive (EU) 2015/863

Based on the relevant requirements of harmonised standards:

- EN 1012-2:1996 +A1:2009 Compressors and vacuum pumps. Safety requirements. Vacuum pumps
- EN ISO 80079-36:2016 Explosive atmospheres – Part 36: Non-electrical equipment for explosive atmospheres. Basic method and requirements
- EN ISO 80079-37:2016 Explosive atmospheres - Part 37: Non-electrical equipment for explosive atmospheres -- Non-electrical type of protection constructional safety "c", control of ignition sources "b", liquid immersion "k"

This declaration, based on the requirements of the listed Directives and EN ISO/IEC 17050-1, covers all product serial numbers from this date on: 2022-04-20

You must retain the signed legal declaration for future reference

This declaration becomes invalid if modifications are made to the product without prior agreement.



Andries de Bock – VP Engineering
Industrial Vacuum Division
Cologne



Jan Vecera – General Manager
Lutín Product Company

Declaration of Conformity

Edwards Ltd
Innovation Drive
Burgess Hill
West Sussex
RH15 9TW, UK

Documentation Officer
documentation@edwardsvacuum.com

This declaration of conformity is issued under the sole responsibility of the manufacturer.

Product: Drystar Bareshaft Pumps

Models: EDP80, EDP160, EDP250, EDP400

Product Numbers:	EDP80 50Hz	A70545000	EDP250 50/60Hz	A70543000
	EDP80 60Hz	A70547000	EDP400 50Hz	A70542000
	EDP160 50Hz	A70544000	EDP400 60Hz	A70541000
	EDP160 60Hz	A70546000		

The object of the declaration described above is in conformity with relevant statutory requirements:

Supply of Machinery (Safety) Regulations 2008

The objectives of the Electrical Equipment (Safety) Regulations 2016 are governed by Annex 1 1.5.1 of this regulation.

Equipment and Protective Systems Intended for use in Potentially Explosive Atmospheres Regulations 2016

Internal Ex II 1 G Ex h IIB3 T4 Ga

External Ex II 2 G Ex h IIC T4 Gb

INTERTEK Italia S.p.A. NB 2575

ITS03ATEX11396X

Maximum process temperature of +60 °C for high mass flow/ above 100 mbar conditions and +85 °C for low mass flow/ below 100 bar conditions

Ambient temperature is T amb -15 °C to 40 °C

Restriction of the Use of Certain Hazardous Substances in Electrical and Electronic Equipment Regulations 2012

Relevant designated standards or technical specifications are as follows:

EN 1012-2:1996 +A1:2009 Compressors and vacuum pumps. Safety requirements. Vacuum pumps

EN ISO 80079-36:2016 Explosive atmospheres – Part 36: Non-electrical equipment for explosive atmospheres. Basic method and requirements

EN ISO 80079-37:2016 Explosive atmospheres - Part 37: Non-electrical equipment for explosive atmospheres -- Non-electrical type of protection constructional safety "c", control of ignition sources "b", liquid immersion "k"

This declaration, based on the requirements of the listed Statutory Instruments and EN ISO/IEC 17050-1, covers all product serial numbers from this date on: 2022-04-20

You must retain the signed legal declaration for future reference

This declaration becomes invalid if modifications are made to the product without prior agreement.

Signed for and on behalf of Edwards Ltd



Andries de Bock – VP Engineering
Industrial Vacuum Division
Cologne



Jan Vecera – General Manager
Lutin Product Company

ADDITIONAL LEGISLATION AND COMPLIANCE INFORMATION

RoHS (EU, UK): Material Exemption Information

This product is compliant with the following Exemptions

Annex III:

- 6(b) **Lead** as an alloying element in aluminium containing up to 0.4% by weight
- 6(c) Copper alloy containing up to 4% **lead** by weight

REACH (EU, UK)

This product is a complex article which is not designed for intentional substance release. To the best of our knowledge the materials used comply with the requirements of REACH. The product manual provides information and instruction to ensure the safe storage, use, maintenance and disposal of the product including any substance based requirements.

Article 33.1 Declaration (EU, UK)

This product contains Candidate List Substances of Very High Concern above 0.1%ww by article as clarified under the 2015 European Court of Justice ruling in case C-106/14.

- Lead (Pb)
This substance is present in certain brass / aluminium components.

WASTE FRAMEWORK DIRECTIVE (EU)

SCIP Number: d14bc265-84f4-4df4-a1cf-ea15bde45409

Compliance Information – incorporated products and assemblies

Motors	<i>Regulation (EU) No 2019/1781 electric motors and variable speed drives</i> <i>Based in the requirements of harmonised standard:</i> EN 60034-30:2009: Rotating electrical machines -- Part 30: Efficiency classes of single-speed, three-phase, cage-induction motors (IE-code)
Flameproof motors	2014/34/EU ATEX directive on use in potentially explosive atmospheres EN 60079-0:2018: Explosive atmospheres - Part 0: Equipment - General requirements
Fans	2009/125/EC Ecodesign directive requirements for energy-related products Regulation (EU) No 327/2011: Industrial fans driven by motors

Additional Applicable Requirements

The product is in scope for and complies with the requirements of the following:

2012/19/EU Directive on waste electrical and electronic equipment (WEEE)

材料成分声明
China Material Content Declaration

部件名称 Part name 	有害物质 Hazardous Substances					
	铅 Lead (Pb)	汞 Mercury (Hg)	镉 Cadmium (Cd)	六价铬 Hexavalent Chromium (Cr VI)	多溴联苯 Polybrominated biphenyls (PBB)	多溴二苯醚 Polybrominated diphenyl ethers (PBDE)
铜管管件 Brass pipe fitting	X	0	0	0	0	0
铜接头 Brass connectors	X	0	0	0	0	0
<p>O: 表示该有害物质在该部件的所有均质材料中的含量低于 GB/T 26572 标准规定的限量要求。 O: Indicates that the hazardous substance contained in all of the homogeneous materials for this part is below the limit requirement in GB/T 26572.</p> <p>X: 表示该有害物质在该部件的至少一种均质材料中的含量超出 GB/T26572 标准规定的限量要求。 X: Indicates that the hazardous substance contained in at least one of the homogeneous materials used for this part is above the limit requirement of GB/T26572.</p>						